

dissembler

Small Scale Computing Since 1983

Supporting the *Trailing Edge of Technology*

AMR\80552



# The Computer Journal

Issue Number 78

Spring 1996

US \$4.00

Reader to Reader ..... Letters and messages

Real Computing ..... Small-C, C-64, Win95

The European Beat ..... GIDE and KC-85

6502 ..... DIY board

XT Corner ..... Forth, Internet, and GUI

Simplex III ..... Homebuilt TTL CPU

Center Fold ..... A

DIS-100 ..... Messages and Mail

Small System Support ..... C an

Program This ..... 8051 Startup Code

Computer Corner ..... PLD's, linux and embedded

**ENGINEER ALERT**

**AAVVIBSOMO & COMPUTER**

Perfect for Project or Product

••••• INCLUDES •••••

<p><b>KEYBOARD (17-x7"x2.5")</b></p> <ul style="list-style-type: none"> <li>- Durable Plastic, 66 Keys</li> <li>- 2 Connectors for Joysticks</li> </ul> <p><b>ENCLOSURE &lt;IB-sxiix4-5</b></p> <ul style="list-style-type: none"> <li>- Contains Power Supply Motherboard</li> <li>- Front: ON/OFF &amp; Reset Switches, LEDs</li> <li>- Back: 7 Connectors A 4 1/0 Panels</li> <li>- Metal case, Effective RF Shielding</li> </ul> <p><b>ROVER SUPPLY</b></p> <ul style="list-style-type: none"> <li>- 40 Wette AC/OC Switching</li> <li>- SVO2.5A; +12V@2.0A; -12V00.1A</li> </ul> <p style="border: 1px solid black; padding: 2px;">Beautiful Charcoal Grey Design! Special Computer Journal Prices 1</p>	<p><b>MOTHERBOARD</b></p> <ul style="list-style-type: none"> <li>- 4 MHz Z60A</li> <li>- 64K Dynamic RAH</li> <li>- AK/BK EPROM</li> <li>- THS 9918 Video Display (16K)</li> <li>- AY-3-8910 Sound Generator</li> <li>- 4 Slots for I/O Cards</li> </ul> <p><b>ORIBOARD. 1/O</b></p> <ul style="list-style-type: none"> <li>• Audio Output</li> <li>• Video Output</li> <li>• CH 3/4 RF Modulator Output</li> <li>• External RF input</li> <li>• Keyboard interface</li> <li>• Printer interface (Parallel)</li> <li>• Serial interface (RS-422)</li> <li>• 4 Card Slots</li> </ul>
---	---

<table border="1" style="width: 100%; border-collapse: collapse;"> <thead> <tr> <th style="text-align: left;">UNITS</th> <th style="text-align: left;">PRICE</th> </tr> </thead> <tbody> <tr> <td>1.....</td> <td>\$250.00</td> </tr> <tr> <td>2.....</td> <td>\$200.00</td> </tr> <tr> <td>4.....</td> <td>\$150.00</td> </tr> <tr> <td>8.....</td> <td>\$125.00</td> </tr> </tbody> </table> <p><b>KART COMPUTERS</b> P.O. Box 144 Millbury, Ma. 01527 (508)755-9778</p>	UNITS	PRICE	1.....	\$250.00	2.....	\$200.00	4.....	\$150.00	8.....	\$125.00	<p><b>L SUPER J P SPECIAL n.</b></p> <p>INTRODUCTORY</p> <p>UNIT PRICE</p> <p><b>\$125.00</b></p>
UNITS	PRICE										
1.....	\$250.00										
2.....	\$200.00										
4.....	\$150.00										
8.....	\$125.00										

\* Ask for your free copy of "10 Ways to Simplify Programming"

## Hiding in Plain Sight...

Some of the most interesting, challenging programming is being done outside the prevailing paradigms. It's been this way for years, and some companies regard its SPEED, COMPACTNESS, EFFICIENCY and VERSATILITY as their private trade-secret weapon.

It has penetrated most of the FORTUNE 500, it's a veteran in AEROSPACE, it's in SPARC WORKSTATIONS, and it's how "plug and play" is implemented in the newest POWER PCs. In fact, it's lurking around a lot of corners.

It's FORTH. Surprised? Call now to subscribe\* and learn more about today's Forth.

**Forth Dimensions**  
**510-89-FORTH Fax: 510-535-1295**

\*Ask for your free copy of "10 Ways to Simplify Programming"

## Kibler Electronics

Serving the  
Industrial Electronics Community  
since 1978

Specializing In  
Hardware Design and  
Software Programming

*Previous Projects include:*

- PLC ladder programming (15,000 lines)
- 8051 Remote I/O using MODBUS
- 6805 Instrumentation Controller
- 68000 Real Time Embedded Operations
- NETBIOS programming and Debugging
- Forth Projects and Development
- HTML Design and programming
- Articles, Training, and Documentation

Bill Kibler  
Kibler Electronics  
P.O. Box 535  
Lincoln, CA 95648-0535  
(916) 645-1670

e-mail: [kibler@psyber.com](mailto:kibler@psyber.com)  
<http://www.psyber.com/~kibler>

## SAGE MICROSYSTEMS EAST

Selling and Supporting the Best in 8-Bit Software

Z3PLUS or NZCOM (now only \$20 each)  
ZSDOS/ZDDOS date stamping BDOS (\$30)

ZCPR34 source code (\$15)

BackGrounder-ii (\$20)

ZMATE text editor (\$20)

BDS C for Z-system (only \$30)

DSD: Dynamic Screen Debugger (\$50)

ZMAC macro-assembler (\$45 with printed manual)

### Kaypro DSD and MSDOS 360K FORMATS ONLY

Order by phone, mail, or modem and use  
Check, VISA, or MasterCard. Please include  
\$3.00 shipping and Handling for each order.

## Sage Microsystems East

1435 Centre Street  
Newton Centre MA 02159-2469  
(617) 965-3552 (voice 7PM to 11PM)  
(617) 965-7046 BBS

## The Computer Journal

**Founder**

Art Carlson

**Previous Publishers**

Bill D. Kibler

Chris McEwen

**Editor/Publisher**

Dave Baldwin

**Technical Consultant**

Bill D. Kibler

**Contributing Editors**

Herb Johnson

Charles Stafford

Brad Rodriguez

Ronald W. Anderson

Helmut Jungkunz

Frank Sergeant

Richard Rodman

Tilman Reh

*The Computer Journal* is published six times a year and mailed from *The Computer Journal*, P. O. Box 3900, Citrus Heights, CA 95611, (916) 722-4970.

Opinions expressed in *The Computer Journal* are those of the respective authors and do not necessarily reflect those of the editorial staff or publisher.

Entire contents copyright © 1996 by *The Computer Journal* and respective authors. All rights reserved. Reproduction in any form prohibited without express written permission of the publisher.

**Subscription rates** within the US: \$24 one year (6 issues), \$44 two years (12 issues). Send subscription, renewals, address changes, or advertising inquires to: *The Computer Journal*, P.O. Box 3900, Citrus Heights, CA 95611-3900.

### Registered Trademarks

It is easy to get in the habit of using company trademarks as generic terms, but these trademarks are the property of the respective companies. It is important to acknowledge these trademarks as their property to avoid their losing the rights and the term becoming public property. The following frequently used trademarks are acknowledged, and we apologize for any we have overlooked.

Apple II, II+, Iie, He, Lisa, Macintosh, ProDos; Apple Computer Company. CP/M, DDT, ASM, STAT, PIP; Digital Research. DateStamper, BackGrounder ii, Dos Disk; Plu\*Perfect Systems. Clipper, Nantucket; Nantucket, Inc. dBase, dBASE II, dBASE III, dBASE III Plus, dBASE IV; Ashton-Tate, Inc. MBASIC, MS-DOS, Windows, Word; Microsoft WordStar; MicroPro International. IBM-PC, XT, and AT, PC-DOS; IBM Corporation. Z80, Z280; Zilog Corporation. Turbo Pascal, Turbo C, Paradox; Borland International. HD64180; Hitachi America, Ltd. SB180; Micromint, Inc.

Where these and other terms are used in *The Computer Journal*, they are acknowledged to be the property of the respective companies even if not specifically acknowledged in each occurrence.

# TG J *The Computer Journal*

•W

Issue Number 78, Spring 1996

**Editor's Column..... 2**

And in this issue...

**Reader to Reader..... 3**

**Real Computing.....5**

Small-C, C-64 emulators, and Win95 Review

By Rick Rodman.

**The European Beat.....8**

Putting GIDE to work on the KC-85.

By Helmut Jungkunz.

**CP/M 86 Enters the 90's.....9**

A Patch for CP/M 86

By Kirk Lawrence

**6502.....10**

DIY board

By Doug Beattie

**XT Corner..... 15**

Large Data in Forth, the Internet, and GUI stuff.

Frank Sergeant

**Simplex III..... 21**

Homebuilt microcoded TTL processor, Part 1.

By Dave Brooks.

**Center Fold.....23**

amr552LC and 8031

**Dr. S-100.....27**

Messages and Mail

By Herb Johnson.

**Small System Support.....31**

C and Assembler

By Ronald W. Anderson.

**Program This!..... 37**

8051 start-up code with interrupts.

By Dave Baldwin.

**TCJ Store..... 41**

Things for sale from TCJ.

**Support Groups for the Classics..... 42**

**Back Issues.....44**

**The Computer Corner..... 46**

PLD's, linux, and embedded.

By Bill Kibler.

---

---

# Editor's Column

## *And in this issue...*

---

---

### **About TCJ:**

The Computer Journal really is a subscriber supported magazine. In a way, it's kind of a large, international computer club. In this issue, there are less than \$100 worth of paid advertisements. For normal newstand magazines, ads pay more 90% of the cost. For TCJ, subscriptions and orders for Back Issues pay more than 95% of the cost of publishing each issue.

The rest of the ads are either exchange ads like the Forth Dimensions ad (they give us an ad in exchange for us running theirs), 'payment' for articles (the only payment the writers receive), or 'public service' ads to tell you where to find things.

The Up-side of this is that you don't have to wade through tons of ads to find the articles. The Down-side is that the next issue can't be printed until we get enough renewals and new subscriptions each time. This means that when renewals are slow, TCJ is slow getting out. On the other hand, TCJ doesn't owe anybody but the subscribers, so it can't be forced out of business. Everybody will get all of their issues, just maybe not as quickly as we had planned. If renewals and subscriptions pick up, we'll get back on schedule.

In order to increase TCJ's income and to make a few items available to our readers, the TCJ Store has been 'opened'. See the TCJ Store page in the back of this issue. In addition to the Back Issues we've always sold, TCJ is now the US 'distributor' for Tilmann Reh's GIDE kits and we can provide the Walnut Creek CP/M CD-ROM at a discount. The one catch is that we have to collect a minimum number of orders for these items before we can supply them to you. It's like the group purchases your computer clubs have done at times. TCJ doesn't have the resources to 'stock' these items for you. Call, write, or email to see what the current status is for these products.

For that matter, CALL and WRITE! I get very few calls and letters. This makes it very hard to tell what you want to see in TCJ.

Bill Kibler has generously provided the TCJ/DIBs BBS with a 630 MB SCSI hard disk where we can collect a huge number of files. The BBS also has a CD-ROM drive now where you will be able to find the CP/M CD-ROM files. These will be on-line as soon as I find a power supply that will boot up the hard drive reliably.

Dave Baldwin,  
Editor

We have Doug Beattie's 6502 DIY board construction project this time. Doug has also provided a 6502 cross-assembler in both MS-DOS and CP/M versions. You'll find those on his Web page and on the TCJ/DIBs BBS.

Dave Brooks has the first of his series on **Simplex III**, his homebuilt TTL processor and Frank Sergeant is back with **Large Data in Forth** and comments about the Internet.

The Centerfold this time has schematics for two 8051 related boards. The fancy one is AMR's **amr552LC board** with the 80C552 from Phillips and the simple one is my **8031 core** schematic. **Program This!** is my article on 8051 startup code for interrupt operation.

Our regulars are here too, with Rick Rodman and **Real Computing**, Helmut with **The European Beat**, Herb Johnson as **Dr. S-100**, and Ron Anderson with **Small System Support**. And last is Bill Kibler with **The Computer Corner**.

*Next Time...*

It looks like #78 will be the Modem Issue. I already have 3 articles on modems including David Goodenough's article on using the AT command strings.

*Other Stuff...*

Here are a couple of items that I thought you'd like to know about.

There is no TCJ reference card this time, but I did find out that MICRO LOGIC still has all of their **MICRO CHARTS** available. These are the plastic charts that many of us have used for years to look up the Z80 instructions when we're programming or debugging. Other CPU's they have charts for are the 8086/88, the 6502, the 8080/85, and the 68000. They also have charts for BASIC, 'C and Unix Shell along with Wordstar, Postscript, 7400 Pinouts, Basic components, and Algorithms. The charts are \$6.95 each and you can get in touch with MICRO LOGIC at (201) 342-6518.

Also available (still) are the **CP/M** versions of the **cross-assemblers** from 2500AD Software. They're not cheap at \$250 each and they're available only on 8 inch disk (!), but they Are still available. Contact 2500AD Software at (719) 395-8683. They also have products for MS-DOS, of course.

The MOR (Morrow Owners Review) newsletter is no MOR, but the **MOR-BBS** is alive and taking calls. Jay Huddleston has been working on it to get PBBS and NZBYE running to his liking on his Morrow system. Call the MOR-BBS at 360-293-8165, 2400-8-n-1.

---

---

# READER to READER

---

---

Letters and News

All Readers

MINI Articles

---

---

From: Jon Titus  
<[JONTITUS@cahners.com](mailto:JONTITUS@cahners.com)>  
Subject: Gary Ratliff's #77 Article

Dear Gary:

Thanks for your interesting article about the TRS-80 computer. I thought I'd add a couple of references to your list and make a correction: :

1. My colleagues and I wrote two books about the TRS-80 for people who wanted to do things with their computer-control things, measure voltages, etc. These books are "TRS-80 Interfacing, Book 1," by J. A. Titus, Howard W. Sams and Co., Inc., Indianapolis, IN. ISBN 0-672-21633-7, 1979, and "TRS-80 Interfacing, Book 2," by J. A. Titus, C. A. Titus, and D. G. Larsen, Howard W. Sams and Co., Inc., Indianapolis, IN. ISBN: 0-672-21739-2, 1980. I'm sure these books are out of print, but they show up at electronic flea markets.

2. Your article states, "The December 1975 issue of Popular Electronics ushered in the computer age for the masses..." I think you're referring to the JANUARY 1975 issue of the magazine which featured the MITS Altair. However, the Mark-8 computer was featured on the cover of Radio Electronics magazine in July 1974, and as far as I can tell, THAT computer was what ushered in the personal computer age. There were several users groups and at least one newsletter prior to the Altair. Granted, the Altair was popular, but the Mark-8 was what got it started.

Jon Titus  
Milford, MA

---

From: Aristarco Palacios Lopez  
<[apl@speedy.coacade.uv.mx](mailto:apl@speedy.coacade.uv.mx)>  
Subject: Wanted and free.

Hi everybody in TCJ!

I received lots of help with my C64. To say thanks I'm giving copies of the SpeedScript code from Compute! magazine. SpeedScript 3.0 for the Atari and the Apple II. And SpeedCalc (a good Lotus 1-2-3 clone) for the Atari. Just send a message to my e-mail address or send a postcard. The issues are dated 1985.

If someone can send me the C64 version of SpeedScript 3.0 (appeared in March 1985) I'd be very grateful.

I'd like to know if someone has a Disk Drive for my Atari 65XE and the Operating System. I'm very interested on buying one.

Finally, thanks to Bill for takin' time to read this and sorry to Emmanuelle Roche. I haven't get the Beetle brochures yet, but I promise I'll send them as soon as possible, OK?

Aristarco P.

-----  
From: Glenn Haydon  
<[ghaydon@taygeta.com](mailto:ghaydon@taygeta.com)>

Hello Dave,

Thanks for the nudge. The computer I use at Stanford lost its motherboard. A new one is on the way - today or tomorrow. I am forwarding all of my email to that and it all bounces!

Yes, I have available THE FORTH ARCHIVE from [taygeta.com](http://taygeta.com) on a CDROM. I am making them one off. \$50 + \$4 + Calif sale tax, from Mountain View Press, Route 2 Box 429, La Honda, CA 94020.

I also have a home page and cata-

log available: <http://www.taygeta.com/jfar/mvp.html>

I should have written long before but that is the way it is. I have a number of old CP/M system including several H89s which I put together years ago. I also have a large library (100s of disks) of CP/M software but have not gotten to it lately. I also have 10 feet of CP/M program documentations - Many things I have not looked at in years.

I originally brought up MVP Forth on one of the old H89s and have migrated it to other platforms. The kernel dates back to 1984 and is unchanged! I would have done some thing differently but I leave it stable as is and still sell it. Almost all of the sales are for the PC. I have added applications to the distribution so that one can compile from text files as well as blocks, and many other things. Contact me.

Of late I have been learning to record CDROMs. It sounds simple, but I have had my problems. I now seem to be able to make them without the freebies.

I am also interested in Linux. I have it up on one of my PCs and like it fine. However, it is certainly not a simple out of the box process. On the other hand it is an introduction to Unix. It works fine and fast on the PC and with the GNU software, one has considerable power!

I still have the WISC CPU/16 and CPU/32 processors. There is ongoing interest in the CPU/16 as a teaching tool at several Universities and Colleges. I have been thinking of putting a description and schematics in the TCJ for non-commercial use. If there is any interest, let me know.

There are other things besides computers in my life and there are just too few hours. Retiring makes it harder, not easier!

Again, thank you for the nudge.

Glen B. Haydon, M.D.  
Rt 2 Box 429  
La Honda, CA 94020  
415 747 0760  
ghaydon@forsythe. Stanford, edu  
-----

Dear Mr. Kibler

Enclosed is a M.O. for \$24.00 to renew my subscription. I have been enjoying this magazine very much. In my issue #70 there are 5 sheets between pages 14/39 and the center fold that are missing. I would appreciate it if you could get them to me so I can finish reading that issue.

I originally subscribed for the hardware and CP/M articles. However lately I find myself going to Ronald Anderson's 6809 articles first. Mind you I don't own a 6809 computer (at least not yet) but since I do most of my real programming in 6502 Assembly I was amazed at how similar they are. I think that I might feel right at home with a good reference guide and macro assembler. Most of my other programming is done in 'C', Pascal, BASIC, COBOL and now Z80 assembler. While I am on the subject of 6502, I was curious as to why I don't see any 6502 articles (not really a complaint).

Now on to other things in issue #71 Aristarco Palacios wrote that he was in search of Commodore stuff (if you haven't already guessed, that's the 6502's I am talking about) his list might be a bit beyond what he wants to pay. Starting with the harddrive, current prices for Commodore compatible harddrives are to say the least overpriced even used. Unless you find someone that's just wanting to dump what they have, you will pay a premium even for used ones. The current NEW price for a CMD 20 meg SCSI drive will set you back about \$299.00 U.S.(maybe a little less) and they are in short supply a 85 meg is about \$490.00 and add shipping to that! I would recommend getting the smallest that was available and adding a second APPLE compatible SCSI external drive as large as you need and use the CMD drive as a interface. GEOS for the C-64 and C-128 is about \$45.00. The rest of the list I don't know what the used prices will be you'll just have to make your best deal. I do know where you

might try. For new/used you can try :

Commodore Country  
RT I BOX 333  
Burlson, Texas 76028  
Phone 1-817-295-7658  
1-800-676-6447 <- this might not  
work from Mexico!

In the used only category a fellow in the users group I belong to is selling all of his Commodore stuff you can contact:

Midessa Commodore Users Group  
2411 W. Francis  
Midland, Texas 79701

Ask that the letter be given to John Michael. I don't think they will do you wrong. However if you want a warranty Call Commodore Country. I have dealt with them and have been satisfied with their service.

Well enough Commodore, I noticed that you were collecting BIOS source files. I think somewhere I have source for my ALTOS 8000 but it will be on an ALTOS 8" disk and although I can copy it, I can't get it to another format. If you would like I'll set up my ALTOS and make you a copy and sent it to you. While I am thinking about the ALTOS, do you know of a place to get a harddrive that would be a compatible replacement for a QUANTUM 2020. The one in my ALTOS has expired and with a single disk drive it's a real pain to use.

A while back I received my copy of the CP/M CD-ROM and have had quite a time going through all the files. I recall in a back issue of TCJ that something was said about a NON CP/M NON MS-DOS CD-ROM was being considered, has anything come of that?

Well I am going to stop here, it's midnight and I have a full day ahead

Thanks for the great mag...  
Ronald Austin  
706 N. Carroll  
Spur, Texas 79370  
-----

Dear Dave,

I wonder if any of your subscribers have any information on the "Legacy" Real Time Clock which was used in the Kaypros? I would welcome any documentation and, if possible, a copy

of the program which runs with it.  
I look forward to your next issue.

Alwyn Stockley, KJ7DA  
P.O. Box 1764  
Sisters, OR 97759  
-----

Dear Dave,

Thanks for putting the Z80 Reference Card in the latest issue. I checked over the instruction cycle times, and my modification to William Colleys' compiler had the wrong time for the "Id (nn),hl" instruction. Should have been 16, but I had 20. However, I think their "pop ix" and "pop iy" instruction times were incorrect. Shouldn't they have been 14 cycles instead of 15?

Frank Wilson  
P.O. Box 55  
Tomales, CA 94971  
-----

From: "Ronald W. Anderson"  
<[rwilanders@provide.net](mailto:rwilanders@provide.net)>  
Subject: Prime Numbers

Dave,

There has been a rather lively dialogue (or should I say quintalogue or hexalogue) among the TCJ authors regarding the Prime Number program presented in issue #77 by me. I thought the readers might like to be in on it so I'll digest it here as a letter to the editor.

First, a couple of people said that 1 is not a prime number. I won't argue the point. It qualifies because it is divisible only by 1 and itself, but perhaps since 1 and itself are the same it is a special case.

I had reported times of execution on a 50 MHz 486-50 SLC/2 as follows:

Limit #primes	Seconds	
250,000	22,044	80
500,000	41,538	227
1,000,000	78,498	602

The number of primes differs from those in the article by 1 because of the exclusion of 1 as a prime. John Baker coded the program and ran it on his Amiga 500 running a 14.3 Megahertz 68000. His times:

*continued on Page 20*

---

---

# Real Computing

By Rick Rodman

32-Bit Systems

All Readers

Small-C, C-64, WIN95

---

---

## Small-C in PROM

For small embedded controllers, we've typically had to use assembly language. However, for some CPUs, Small-C offers reasonable code efficiency, so if you can live within its syntactical limitations (no longs, structs, or multidimension arrays, among other things), you can use Small-C for your embedded projects.

In this example, the hardware is Brad Rodriguez' Scroungemaster board, the C is from C User's Group volume 309, and the processor is a Motorola 6809. Small-C generates assembly language, so you need an assembler too. The assembler I used in this case is called AS9, and comes with source code in C. It's a fairly simple assembler which does not support linking.

The first thing you have to do is to modify the startup logic for your particular hardware. In this case, the startup logic is contained in a header file called "startup.h". Since no linking is possible with AS9, all header files include actual functions within them. This means you'd better watch out what you're including if you're concerned about code size! The Scroungemaster has 32K of PROM space, however, so there's no need for concern there.

My modified startup.h file is in listing 1, space permitting, and the whole package from this article is on the KPCF BBS. Note the initialization routines for the Scroungemaster's memory mapping, and the ORG and stack addresses.

A tricky issue with C going into ROM is static data. If you have initialized static data, it must be initialized before the program starts. It gets worse - you might have pointers which need to be initialized with addresses. This is where relocation becomes a real hassle. The simplest thing to do about these things, in the firmware world, is to disallow them. You can initialize your data structures yourself in C code.

C programmers often assume that static data is initialized to zero by someone else before the program loads. Well, in the firmware world, there isn't anyone else. Do it yourself if it's that important to you.

Where does static data come from? It usually comes from

what Real Programmers disparagingly call "global variables." Unfortunately, in most real projects it's almost impossible to avoid using some global variables. The problem in this case is that AS9 doesn't support separate "code" and "data" origins. Using this assembler, if you declare a global variable, it'll be in PROM. That takes care of the initialization problem, anyway... While a "no global variables" restriction appears harsh, I'd rather work around it or fix it than switch assemblers, because to me, having source code to everything is worth it. Your feelings may vary.

A nice thing that Small-C lets you get away with is very free interchange of ints and pointers. For example:

```
#define:BUFFER 0x2000
*(BUFFER + i) = '0'; ;
```

Of course, Small-C is just a language. You may still need a tick interrupt for real-time work, hardware-interface drivers, and other things.

On a bigger project, Small-C's syntax will be too limiting. NS32 developers can use Phil Prendeville's C, available from KPCF. For other processors, Dunfield Development Systems offers the Micro-C compiler and development package which implements most of ANSI C.

And you'll notice that all of these tools are running on a PC or Sun or some other "development platform", with PROMs being burned for a "target platform". This is a cross-development facility. At present, there isn't any simple platform available for native embedded system programming in C analogous to Forth or TDS.

My intention is to use this setup to develop a PROM-based version of TinyTCP to use on small embedded computers. By means of a serial router and/or Little-Net interface, I'll be able to "telnet" into each controller and interact with it remotely. Secondly, controllers will be able to send data streams to one another through TCP connections. More on this project will be dribbling out in future columns.

Commodore 64 emulators

There is a whole world of activity going on on the Internet related to Commodore 64 software emulators. If you have a

lot of C64 software (as I do), you may want to look into this. When Bill last mentioned this topic, you needed a Hercules board. Since that time, there are several new emulators available, and an Internet newsgroup dedicated to them, comp.emulators.cbm. Here's some basic information from the group's FAQ (frequently asked questions file).

The emulator Bill described is called C64, by Johannes Kiehl. A newer emulator, C64S by Miha Peternel, is considered much better, and is available in a "shareware" and a commercial version. It requires a 386 or better and a VGA. A similar emulator from Germany is PC64 by Wolfgang Lorenz. Under development is C64 Alive by Frank Littman, as well as Windows versions of PC64. Several C64 emulators are available for the Amiga as well.

But how do you get your C64 programs to your PC? By means of a cable connected from your parallel port to a 1541 or 1571 disk drive. Several utilities are available to do the transfer, which basically amounts to making a sector-by-sector image of each diskette (with filetype .d64) on your hard disk. Because of the group-coded format used by the 1541, you can't read C-64 disks on your PC's drive.

### Windows 95

Here's your official *TCJ* review of Windows 95. I installed it on a 486DX-33 with 250MB hard disk and 4MB of RAM. Microsoft would consider this machine, a monster in 1992, only a minimal configuration for Windows 95. Windows 95 takes a long time to install, to boot, and to do much of anything else. The "Install Wizards" are very slow, and irritatingly stupid besides. Most Windows programs I tried worked, but many DOS programs would not work, especially communications programs - they just freeze up. My recommendation is, if you've got 8MB of RAM or more, and you've got to run DOS or Windows programs, use either OS/2 Warp or Windows NT. I don't see any reason for anyone to run Windows 95.

### Computer telephony

Everyone's so breathlessly enthused about the Internet and how much money it's going to make for them. It reminds me of the seventies, when everyone told me that there was so much money out there in the computer field. Where, exactly, I never could find out.

Anyway, some exciting stuff has been happening in computer telephony too. There are new voice boards available which make it possible to set up simple voice-response systems fairly inexpensively. I've been fiddling with some new stuff in this area, but don't have enough to report (or room left to report it, for that matter).

### Next time

The data-stream concept for building distributed computing systems.

### For more information

Kettle Pond Computing Facility  
BBS or Fax: +1 703 759 1169  
E-mail: [ricker@erols.com](mailto:ricker@erols.com)  
Mail:  
1150 Kettle Pond Lane  
Great Falls VA 22066-1614

Microsoft Corporation  
One Microsoft Way  
Redmond WA 98052-6399

Dunfield Development Systems  
(Micro-C for 6809, 68HC11, 8051, 8080, 8086, 8096)  
P.O. Box 31044, Nepean, Ont. K2B 8S8  
Phone: +1 613 256 5820  
Fax: +1 613 256 5821  
BBS+1 613 256 6289

Seattle Lab (C64S commercial version)  
214 First St., Kirkland, WA 98033  
+1 206 828 9001  
fax+1 206 828 9011  
email [lab@seattle.wa.as.com](mailto:lab@seattle.wa.as.com)

Ted Drude  
(US contact for PC64, \$30. Cables, manuals available.)  
103 Belle Circle, Madison, AL 35758  
email [teddrude@delphi.com](mailto:teddrude@delphi.com)

*PS: I got a surprise the other day when a developer sent me an email message about a New add-on product he was working on for the Commodore 128. When I asked him about it, he said a number of new products had come out recently. One was an accelerator board that bumped the clock speed up to 20 MHz! DB.*

**LINUX**

InfoMagic 5 CD Set.....	\$21.95
Yggdrasil.....	\$29.95
Linux man Pages.....	\$29.95
The New Book of Linux.....	\$29.95

Call for other titles

[www.justcomp.com](http://www.justcomp.com)  
*on the World Wide Web*

**JUST COMPUTERS!**  
**(800) 800-1648**

Fax (707) 586-5606 Int'l (707) 586-5600  
P.O. Box 751414, Petaluma, CA 94975-1414  
E-mail: [sales@justcomp.com](mailto:sales@justcomp.com)

Visa/MC/Int'l Orders Gladly Accepted  
For catalog, send e-mail : [info@ju.stcomp.com](mailto:info@ju.stcomp.com)  
Include "help" on a single line in the message.

LISTING 1: STARTUP.H FOR SCROUNGEMASTER II

```

/* startup.h used to generate startup code for C6809
*/
/* 960212 rr mods for AS9, Scrounge */

#asm
ORG $fffe
FDB $8000 * Address of EPROM
ORG $8000
lds #$3FFE * Set stack at top of RAM

* set up memory map of scroungemaster

cl ra
sta $F000 * map FFxxx into 7xxx - 1/0 and RAM
i nca
sta $E000 * map FExxx into 6xxx - RAM
i nca
sta $0000 * map FDxxx into 5xxx
i nca
sta $C000 * map FCxxx into 4xxx
i nca
sta $8000 * map FBxxx into 3xxx
i nca
sta $A000 * map FAxxx into 2xxx - RAM (8K chip
                * alias address)

inca
sta $9000 * map F9xxx into 1xxx
i nca
sta $8000 * map F8xxx into 0xxx

* Init SCC ports A and B

idx //sccatbl                * port A setup table
bsr sccinit
idx //sccbtbl                * port B setup table
bsr sccinit

* Go to user program

jmp main

* Zilog SCC initialization routine.

sccinit:
idy ,x++                    * get SCC port address
idb ,x+                      * get // bytes to output
sccloop:
lda ,x+                      * get a byte from the table
sta ,y                       * store it to the SCC control
port
decb
bne sccloop
rts

```

```

sccatbl:
FDB $7002 !                 * SCC A command address
FCB 37                      * 37 bytes follow
FCB $00                     * just in case, reset reg ptr
FCB $09,$C0                 * hardware reset, interrupts off
FCB $4,$44                  * 16x clock,async,1 stop.no par.
FCB $1,$0                   * no dma. all irpts disabled
FCB $2,$0                   * irpt vector (for future use)
FCB $3,$0c0                 * rx 8 bits, rx disabled
FCB $5,$60                  * tx 8 bits, tx disabld, RTSA hi
FCB $9,$1                   * status low, irpts off
FCB $0a,$0                  * nrz encoding
FCB $0b,$50                 * no xtal, BRG->rx c txc, TRxC in
FCB $0c,$18                 * BRG lo byte - 4800 baud at 16x
FCB $0d,$0                  * hi byte - w/ 4 MHz BRG elk
FCB $0e,$2                  * DTR pgm'd. BRG from PCLK
FCB $0e,$3                  * as above, plus BRG enabled
FCB $3,$0cl                 * as above, plus rx enabled
FCB $5,$68                  * as above, plus tx enabled
FCB $0f,$0                  * no ext/sts interrupts
FCB $10,$10                 * reset ext/sts interrupts twice
FCB $1,$0                   * no dma, all irpts disabled

```

```

sccbtbl:
FDB $7000 !                 * port B command address
FCB 31                      * 31 bytes follow
FCB $0                      * just in case, reset reg ptr
FCB $4,$44                  * 16x clock.async.1 stop.no par.
FCB $1,$0                   * no dma, all irpts disabled
FCB $3,$0c0                 * rx 8 bits, rx disabled
FCB $5,$60                  * tx 8 bits, tx disabld, RTSB hi
FCB $0a,$0                  * nrz encoding
FCB $0b,$50                 * no xtal, BRG->rx c txc, TRxC in
FCB $0c,$18                 * BRG lo byte - 4800 baud at 16x
FCB $0d,$0                  * hi byte - w/ 4 MHz BRG elk
FCB $0e,$2                  * DTR pgm'd. BRG from PCLK
FCB $0e,$3                  * as above, plus BRG enabled
FCB $3,$0cl                 * as above, plus rx enabled
FCB $5,$68                  * as above, plus tx enabled
FCB $0f,$0                  * no ext/sts interrupts
FCB $10,$10                 * reset ext/sts interrupts twice
FCB $1,$0                   * no dma. all irpts disabled
*
FCB $9,$9                   * as above,plus irpt master
* enable

```

\* Following was C.AS9, with minor formatting changes

(This portion of listing deleted for clarity, since C.AS9 is present in the distribution and is not machi ne-speci fi c.)

```

//endasm

/* end of startup.h */

```

---

---

Regular Feature

All Users

East German Z80 + GIDE

---

---

# The European Beat

by Helmut Jungkunz

## Putting the GIDE to work on the KC

Ever since the advent of Tilmann's GIDE, many CP/M systems have gone through wondrous changes. Slowly, the circle of happy hard disk users has been growing. But even though things have become much easier with the GIDE, implementing the software side still means lots of work -and a skilled programmer.

One of the great dilemmas is the fact, that many Z80 CPUs are soldered in! This is the point, where it comes down to determine between filigrane operation and mere butchering. Beware! Your CP/M computer is not a cat and therefore does not have nine lives!

In the case of the East German KC 85/4 (remember -I wrote about it before) the CPU is a UA 880, a true clone of the famous Z80. In such a case, best get a spare CPU first, for the UA 880, a Z80 will perfectly do. The soldered-in processor must be cut out, pin by pin. This makes it easier to remove the leftovers. After cleaning the holes with a solder pump or the like, it is best to fit a socket in its place. This will also be the home for the GIDE interface. If the small contact "eyes" get too much heat, they will get destroyed, leaving the computer useless. Users with little experience might try soldering the socket directly to the leftovers of the pins, to avoid overheating the circuit board itself.

The physical position of the GIDE is rather uncritical, in fact, even mounting it upside-down (like in the KC), doesn't make any difference. When considering the size of the future hard disk, the often desired "small" sizes of 40 to 80 MBs are harder to get every month, so move quickly! It is advisable to always use a separate power supply for the hard disk, since most CP/M power supplies are probably too weak to take up more load. This is especially the case with the "D004", the main unit of the KC.

Typically, configuring the BIOS for the IDE drive is done like patching any CP/M for various sizes. Only that a table has to be designed for the Disk Parameter Block (DPB) to hold the IDE drive characteristics. With the KCs, though, we are facing a truly exotic operating system. It has its origin in a Moscow institute and returns a version number of 2.6! This is due to the fact, that some features of CP/M Plus were supposed to be integrated already. This MicroDOS, however, is not like any regular CP/M at all. Needless to say, no source comes with the machine. Experts from the KC user group tried reverse engineering, but were quite

puzzled with the bland mixture of code, they found. Mario Leubner, chief wizard of the assembler crew, commented each and every routine found, resulting in 400K of text!

Gradually, MicroDOS revealed its secrets. Basically, there are 4 parts: a KC-specific BIOS, a MicroDOS BIOS, a MicroDOS-BDOS and a MicroDOS CCP. The three latter obviously are of Russian origin. They contain many unused and undocumented functions from CP/M Plus. To make things worse, the parts are not clearly separated, but all mixed-up with each other.

Mario's first grand deed was then, to eliminate this cross-assembly and to reduce all this to CP/M format. The IDE and the Realtime Clock were integrated into the BIOS, like with any other system, as well. A lengthy debate by email between Joerg Linder and myself resulted in choosing ZSDOS as BDOS replacement. Unfortunately, the included INST ALOS could not be used, since there is no MOVCPM. (I recommended using the file \CPM\BDOS\DOSPLSOR.ARK from the CP/M CD-ROM, where sources for MOVCPM and SYSGEN are found.) For CCP, he is using a minimal version from scratch, derived from the resourced code. The new system offers 4B larger (!) TP A. Mario has been using his 42MB drive for a while already. Since the RAM-disk of the KC is only addressable via a coupling RAM of only 128 Byte size, the hard disk access is even faster.

The next step is to integrate the clock driver into the system, so DATESTAMPER can be used. (When I first passed the idea and praised the advantages of true datestamping, Mario and lots of others were against it. It works out, that Mario now is one of the hard-core fans of datestamping!) For CCP, ZCPR34 or maybe the patched ZCPR40 will be integrated into the OS. It will be one of the best Z80 operating systems, maybe the best one - after the CP/M Plus of the CPU280 (says Joerg Linder).

I'd like to thank Joerg for his precious input for this article, I am happy, to have been of assistance, and we all hope, the KC user's have good luck with their new CP/M hard disk machines.

Regards  
Helmut

This may be completed by a report from the KC user meeting after the 10th of March.

---

# CP/M 86 Enters the 90's

by Kirk Lawrence

Special Feature

Intermediate

CP/M 86 Patch

---

Run CP/M-86 on a Pentium-based IBM clone? Yes, it's now possible. A simple patch has been found that enables CP/M-86 to run on any AT-class computer. It's an interesting new discovery which just might breathe some extended life into this presumed-dead operating system.

To experienced CP/M-86 users, it'll seem like a miracle. Because if you've ever tried to run CP/M-86 on an AT-class IBM-compatible computer, you've already discovered the sad truth: it doesn't work. Attempting to boot this teen-aged O.S. on any AT-class machine results in an "Unexpected Interrupt" error message on the status line. Then everything shuts down.

Now, in all fairness, it must be noted that "CP/M-86 for the IBM PC and IBM PC XT, Version 1.1" was never intended to run on AT-class computers. But as processor technology advanced throughout the 1980's, CP/M-86's incompatibility with the AT became increasingly problematic. The operating system wasn't all that popular even in its heyday, and its inability to run on an AT was just one more nail in its rapidly-closing coffin. Mainstream computer users were moving to AT-class machines, and CP/M-86 couldn't follow.

Nonetheless, a few of us die-hard CP/M-86 fans stuck around. In 1993, while cruising various CP/M BBSes around America in search of CP/M-86 software, I happened to electronically "meet" Richard Kanarek ([72371.lll@compuserve.com](mailto:72371.lll@compuserve.com)). He and I began to correspond by e-mail, and he soon became a fellow CP/M-86 aficionado. We periodically exchanged messages about CP/M-86's AT phobia.

Then one fateful day in November of 1995, Richard Kanarek decided to take on the daunting task of trying to determine why CP/M-86 won't boot on an AT-class computer. Ultimately, his sleuthing turned up the cause of the problem — and, more importantly, a "fix" for it. This is an amazing and brilliant piece of detective work, and should certainly earn Richard his own page in the annals of CP/M esoterica. Thanks to the diligent efforts of Mr. Kanarek, we now know why CP/M-86 won't boot on an AT-class machine. At boot-up, CP/M-86 installs a default interrupt service routine (ISR) for interrupts 20h through 32h, and 41h through A0h. One can only speculate as to why Digital Research built the system that way; possibly to insure that control would be returned to CP/M-86 if one of those off-limits interrupts should be called by some renegade program gone awry.

The presence of the ISR is perfectly acceptable to PC and XT class computers, because they normally don't use the interrupts which the ISR traps. However, in an AT-class machine, it appears that the computer itself generates one or more of these "forbidden" interrupts for its own internal purposes during boot-up. When this happens, the ISR is triggered, the infamous "Unexpected Interrupt" message is generated, and CP/M-86 attempts to return control FROM itself back TO itself — resulting in a system lock-up.

Of course, knowing the cause of the problem is one thing. But finding an after-the-fact "fix" is quite another. Richard Kanarek concluded that the most direct solution to the problem would be to prevent CP/M-86 from installing its default interrupt service routine in the first place. As luck would have it, he was ultimately able to do this by altering only TWO BYTES within the CPM.SYS file.

Here, for your edification and enjoyment, is the magic AT compatibility "patch" for CP/M-86: simply change the bytes at offset 3DAFh and offset 3DB9h in the CPM.SYS file from "AB" (a STOSW instruction) to "47" (an INC DI instruction). This disables the installation of the default ISR, and allows the "patched" version of CPM.SYS to boot and run perfectly on any AT-class computer. Incidentally, the patched system file will work just fine on PC and XT class machines, as well.

An easy way to make the patch is to transfer the CPM.SYS file over to DOS (using Sydex's shareware program 22DISK, or any other software designed for converting files between disk formats). Then, using Norton Utilities or any byte-level editor, change the two bytes as described above. Save the changes to disk. Finally, transfer the patched CPM.SYS file back to a CP/M-86 formatted double-density floppy disk, and you're all set. Shove that floppy into the A: drive of your favorite AT-class machine, and boot from it. Bingo! You're off and running.

Please understand that this patch is specific to "CP/M-86 For The IBM PC and IBM PC XT, Version 1.1." The file offsets won't correspond with any other version or permutation, so don't try it with Concurrent CP/M-86 or with any of the non-IBM O.E.M. versions of CP/M-86.

*Continued on Page 14*

Special Feature

All Readers

6502 Design

# 6502 DIY Board

by Doug Beattie

There are many eight-bit processors, which have been around for a long time. One of these is the 6502, which has been used in a number of home computers. The 6502 is an ideal processor for a prototype. It is also quite affordable.

## The 6502 prototype

A prototype is a basic model from which to build and expand upon. It allows us to evaluate and analyze a minimum system. With a prototype, we can study the operation of components functioning as a system. This allows us to gain experience with the components, and better understand how they work. It would be difficult to study a component in detail without using it as part of a system.

As an example, perhaps there is a particular RS232 communications chip you wish to learn more about. It is not practical to use the chip all by itself. We connect it to other chips (components) and utilize its ability to communicate. If it is a chip we haven't used before, then we must learn to "speak its language," learn how it operates. One practical way to do this is with other computer chips, on a little circuit board, working together as a system. This type of system is often referred to as a prototype.

The 6502 prototype board is surprisingly easy to build, and if you build it on a bigger board than is needed, it can be expanded and enhanced later. After you understand the minimum system (your prototype) you can add other things like a printer port, floppy drives, and even a hard disk, CD-ROM, plotter, or whatever.

At first, we want a real feeling for the capabilities of the 6502 prototype board, so at least let's have a keyboard, and a video screen to communicate with it. A computer terminal does both. If you have a TRS-80, you could use that as well. I also remember somebody mentioning once that a dumb terminal was a perfect application for a PC. All we do is run QMODEM or TELIX or PROCOMM or whatever... and instead of initializing a modem and dialing it, we fire up the little computer board and compute on it.

## Overview

This is the computer board; you should build it. It's just a prototype, but the potential is here to expand and modify into many useful things. It consists of the following circuit chips:

6502 CPU - the heart or "engine" of the system.

2K or 8K EEPROM (jumper selectable) - a special type of Read-Only Memory, also known as "E-2-prom," this is like EPROM but no dangerous ultraviolet rays are required to erase the chip. It is erased electronically.

32K Static RAM - usually called "S-ram," static RAM is simple to interface.

6522 VIA (Versatile Interface Adapter) - combination of two parallel I/O ports (each with eight synchronized lines, like for a printer device), and timers. Timers are useful for one-shots or counting duration, or alarms for overtime, etc.

One-shots: something happens for a precise timed duration. It might be a length of a tone, squirt of fuel or a douse of water, or a shot of air.

Duration: how long something happens .. perhaps how long after dawn your street light finally decides to go off. How long it takes your little heater to heat the backyard pool up to comfy.

Alarms (time-out): been in the freezer room for too long? an alarm sounds.

6551 ACIA - the Asynchronous Communications Interface Adapter. Don't let the long technical name fool you. It's fairly simple. Basically, it provides the interface to a modem or to another computer.

The ACIA connects your terminal to the computer board, so you can interact with your computer board, update information, set parameters of operation, duration of timing, error correction factors, etc.

Basically, that's it... CPU, RAM, ROM, VIA and ACIA

## Other Chips

The 7404 (chip U2) is an inverter. It produces a high level from a low input, and a low level from a high input. The 74LS139 (chip U3) is similar to the popular 74LS138, but instead of producing eight signals from three lines, it pro-

duces four signals from two lines. The 74LS139 also includes two identical decoders within one package.

The MAX233 (chip U7) is a single-chip solution for RS232 line drivers/receivers, producing the proper voltage transitions between 5-volt TTL level and 12-volt RS232 level. It is an ideal chip for serial communication when only 2 input and 2 output lines at most are needed. No external capacitors are required, and it draws very little power.

### Theory of operation

System ROM is jumper-selectable. The jumper option allows either 2K ROM or 8K ROM, addressing the 2K option at \$F800, or the 8K option at \$E000. The schematic references an 8K (28-pin) socket, but no distinction is made between the two — either ROM will work effectively if the jumper is set correctly.

Address decoding for upper memory is accomplished using 1/2 of a 74LS139 (chip U3A).

The 6522 VIA is decoded at location \$C000..C00F. Chip selects come from chip U3A and address line A12 (inverted).

The 6551 ACIA is decoded at location \$D000..D003. Chip selects come from chip U3A and address line A12 (true).

The CPU clock comes from a 1\_MHz crystal oscillator. VIA and ACIA clocks are driven from the buffered CPU clock PH2 (for greek letter “phi”, and 2). The ACIA also utilizes a separate 1.8432\_MHz crystal oscillator for baud rate generation.

A full 32K of RAM is located at \$0000..7FFF. Chip select for this RAM is provided by CPU address line A15; when A15 is low, the 32K RAM is selected. Read and write signals are provided by U3B, another 1/2 of a 74LS139.

### Construction

It seems that wire-wrap is the way to go. Now, if you have tried to wire wrap before, and were not successful, this time you should be:

1. because there is a wirewrap list.
2. I drew the schematic to represent the component layout.

You don't HAFTA build it that way, but I tried to make it easy for you. With a few sockets and a perfboard, you can build the prototype.

There is a drawing of where the sockets should go - try to position the sockets on the perfboard according to the diagram. There is a schematic which closely resembles the actual layout.

There is a systematic wire-wrap list - not much more difficult than a dot-to-dot.

There is also a parts list. I picked all parts that are available from Jameco Electronics. Jameco has been around for many years and has competitive prices.

Be sure to use Wrap ID tags. These are worth the extra cost. The task of wire wrapping becomes a smoother process.

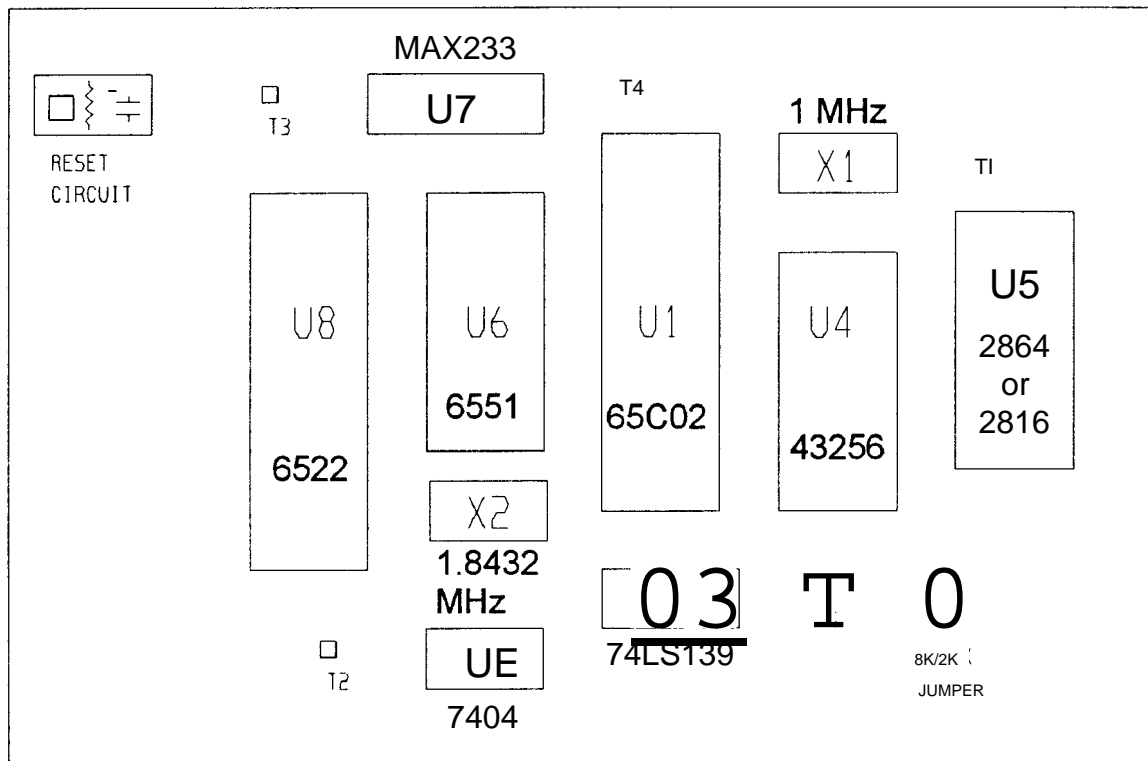

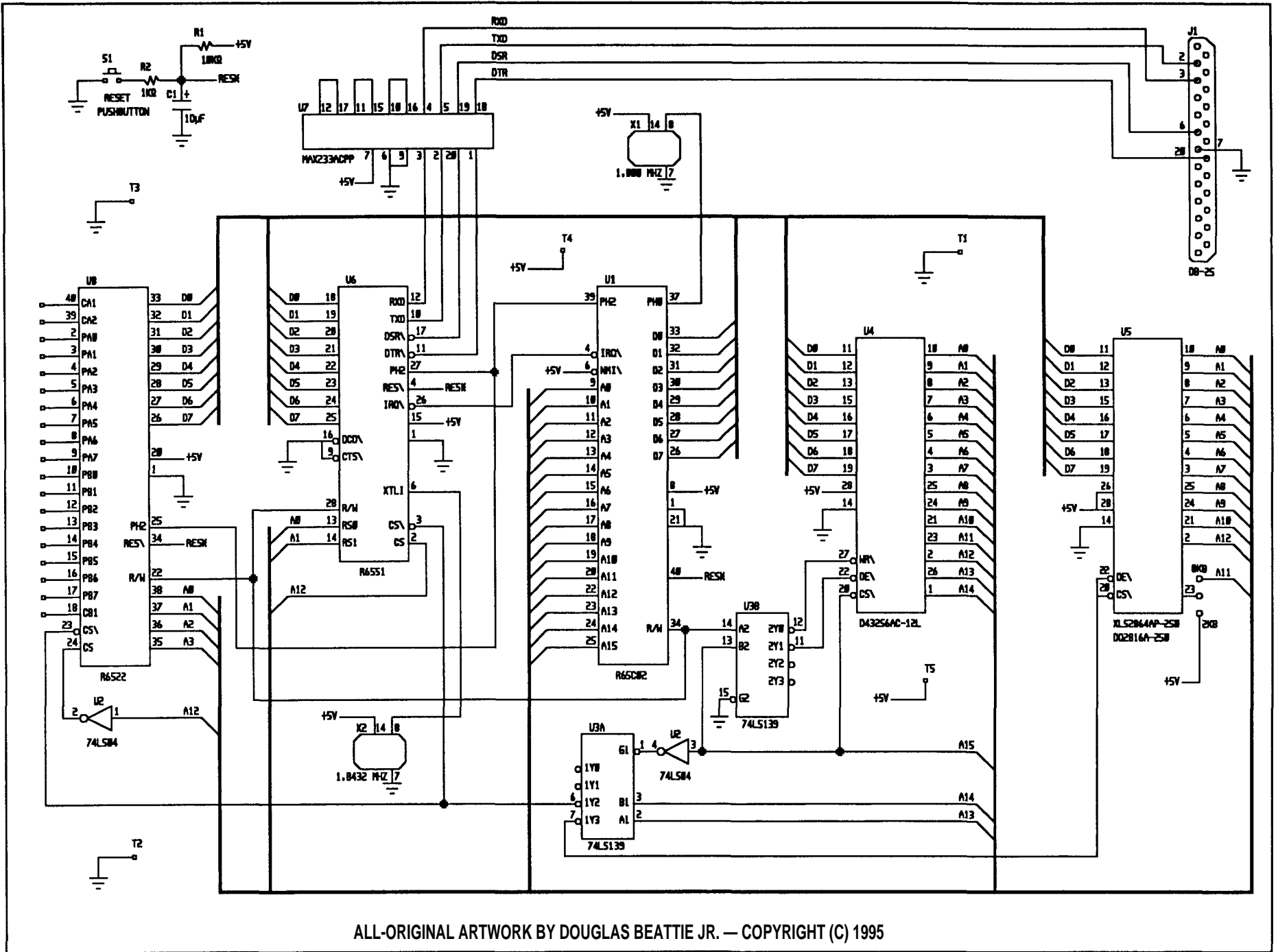

## Parts

The toughest part of this whole project will probably be filling out an order.

Filling in an order form, and punching in all those part numbers is not exactly my idea of fun. Any spreadsheet program makes light of the job. I used a really old version of Lotus 1-2-3 (the one that runs on a PC-XT) — it worked just fine. And evidently Jameco didn't mind. Their service was fast.

Call Jameco for their latest catalog at (800) 831-4242, or e-mail them at [info@jameco.com](mailto:info@jameco.com), or request a catalog through their computer bulletin board at (415) 637-9025.

### Parts List:

- 1 2816A-25 EEPROM, 2K X 8, 250ns (CMOS)
- 1 43256-12L Static RAM, 32K x 8, 120nS (CMOS)
- 1 65C02 MPU with internal clock, 1 MHz
- 1 6522 Versatile Interface Adapter
- 1 6551 Async. Comm. Interface Adapter
- 1 74LS139, 2-to-4 Decoder/Demultiplexer
- 1 74LS04, Hex inverters
- 1 MAX233CPP, +5V powered, Dual RS-232 Txm/Rex
- 1 Crystal Oscillator, 1.8432MHz
- 1 Crystal Oscillator, 1MHz
- 1 TP-2301 Push button switch, 20mA @ 15VDC
- 1 10uF electrolytic capacitor
- 1 Resistor, 10K-ohm
- 1 2852 PCB Prototyping Board, 3.60 x 7.00, 2225 holes
- 4 14-pin Wire-wrap sockets, 2-level
- 1 16-pin Wire-wrap sockets, 2-level
- 1 20-pin Wire-wrap sockets, 2-level
- 3 28-pin Wire-wrap sockets, 2-level
- 2 40-pin Wire-wrap sockets, 2-level
- 1 SMH03 header, 3-pin
- 1 .100" shorting block
- 5 T44 Miniwrap Wiring Terminals
- 3 Wrap ID, 14-pin
- 1 Wrap ID, 16-pin
- 1 Wrap ID, 20-pin
- 3 Wrap ID, 28-pin
- 2 Wrap ID, 40-pin

## Software

If you do decide to build this prototype, and then expect it to do something, it will need two things:

An application - what the computer will be applied to do. Applications can be simple or complex, depending...

A program in ROM. That would be software, but we call it firm-ware when it is programmed into an EPROM or EEPROM. Program development usually requires a cross-assembler. You can also "hand-assemble" without an assembler program.

I wrote a short test program to verify that the board is working. BBOARD.ASM transmits a sequence of "01234567" repeatedly to the serial channel, while at the same time receiving keys through interrupt. Whenever a key is received, it is also re-transmitted to the serial port.

While all this is happening, parallel port B is turning LEDs on and off. This assumes that you have put eight LEDs on the parallel port.

You might wire a 20-pin socket to port B of the VIA (as I have done). By using a ribbon cable with IDC socket plugs on each end, you can do all further experimenting on a breadboard. Use port B, because it can sink more current (handle a bigger load). The test program BBOARD.ASM is only to prove that the board is working. I might provide a follow-up article which will give some more software examples. The source for BBOARD.ASM is on the TCJ Web page and on the TCJ/DIBs BBS.

If you already have a 6502 assembler, then cool. Otherwise, scour the internet; I have found 6502 cross assemblers in any one of six different locations. I also wrote one for IBM-compatibles. This is MAS65.EXE and can be found at my web site, URL:

<http://www.whidbey.net/~beattidp/comput/x65tools/>

If you don't have access to the internet, my advice is GET IT. You have no excuse not to. It is affordable, easy to learn, and readily available. It can be accessed through an x86 PC or a CP/M machine or even a dumb terminal. You probably would use the x86 PC since more cross assemblers are available for the PC. I also saw a CP/M cross-assembler for the 6502 somewhere.

## Applications

You tell me! What would you use a small computer board for? (Note one example above for the deep freezer time-out alarm.) Feel free to send some suggestions via E-mail or Mail. The 6502 prototype is rather powerful; plenty can be done with it.

## More To Come

In the future, we will look at ways to enhance the 6502 CPU, expanding its ability. I will provide functionally equivalent TTL and PLD examples, along with a diagram of the state machine.

## Further Reading

David L. Wagner, Digital Logic, Harcourt Brace Jovanovich Inc., pp 265..275, 1988

Ronald A. Reis, Electronic Project Design and Fabrication, Merrill Publishing Company, pp80..83, 1989

Rodney Zaks, 6502 Applications, Sybex Inc., 1979

Rodney Zaks, Programming the 6502, Sybex Inc., 1980

## References and Data

Rockwell International, R650X and R651X Microprocessors (CPU), Document No. 29000D39; Rev 8; June 1987

Rockwell International, R6522 Versatile Interface Adapter (VIA), Document No. 29000D47; Rev 9; June 1987

Rockwell International, R6551 Asynchronous Communications Inter-face Adapter (ACIA), Document No. 29651N90; Rev 4; June 1987

Rockwell International, R6500 Microcomputer System Programming Manual, Document No. 29650N30A; Rev 3; April 1984

NEC Electronics Inc., Memory Products Data Book, Volume 2 of 2, Document No. 60105-1-V2, 1993

Xicor Inc., X28C64 8K x 8 bit 5-Volt Byte-Alterable E2PROM, document 3583-2.4; 7/24/95

National Semiconductor, LS/S/TTL Logic Databook, 1989

Maxim Integrated Products, +5V-Powered, Multi-Channel RS-232 Drivers/Receivers, document 19-4323; Rev 3; 5/94

### Contacts

Rockwell International  
(714) 833-4600  
<http://www.rockwell.com/>

NEC Electronics Inc.  
(415) 960-6000  
<http://www.nec.com/>

Xicor Inc.  
(408) 432-8888  
<http://www.xicor.com/>

National Semiconductor  
(800) 272-9959  
<http://www.nsc.com/>

Maxim Integrated Products  
(408) 737-7600  
<http://www.mxim.com/>

### About the Author

Douglas Beattie Jr. is an independent consultant with no degree of any kind — he was much too busy studying the minutiae of state machines and combinatorial logic to be sitting in a class-room, learning at a standardized rate. He enjoys reading data-books and scrutinizing waveforms; designing prototypes; preparing technical reports, and documenting his work for future reference. His personal library consists of over 450 books and technical manuals, with not one work of fiction.

Douglas Beattie Jr.  
P.O. Box 47  
Oak Harbor, WA 98277-0047  
email: [beattidp@whidbey.net](mailto:beattidp@whidbey.net)

### CP/M 86 Enter the 90's from page 9

Does throwing away the default ISR adversely affect CP/M-86's performance? Not that I've been able to discover. I've personally tested this patched version on 286, 386, 486 and Pentium-based IBM clones, and haven't encountered any difficulties. Naturally, that's not a guarantee, and your experience may differ. So if you make use of the patch information described in this article, you do so entirely at your own risk and peril.

The only potential problem that's been discovered (and this has nothing to do with the patch itself) involves creating a CP/M-86 partition on some AT-class machines' hard disks. A few of the newer hard disks and/or host adaptors do some ultra-fancy sector-and-track translations. These electronic shenanigans appear to conflict with the way CP/M-86 addresses the hard disk — and in some cases, can prevent a partition from being created properly. But if you're using a fairly "normal" hard disk and controller, chances are you won't have any trouble creating a CP/M-86 partition on most standard MFM, RLL, IDE or SCSI hard drives.

The AT-compatibility patch comes a decade too late to save CP/M-86 from its decline into relative obscurity. But the patch does offer some renewed possibilities for this neatly-crafted and under-rated operating system. Those of us who enjoy keeping it alive can take a bit of comfort in the fact that CP/M-86 has, at last, entered the '90's. Thank you, Richard!

---

---

# PC/XT Corner

## By Frank Sergeant

---

Regular Feature  
Hardware Support  
XT's and More

### Handling Large Data in a Small Forth

My main topic this time deals with the problem of handling a collection of data that is too large to fit in the Forth dictionary. To start off, though, I'll touch on a number of other subjects.

### The Internet

I did sign up with Eskimo North in Seattle for 5 years. My email address there is [pygmy@eskimo.com](mailto:pygmy@eskimo.com). I also paid Pobox for 12 years of email forwarding service. This should make [pygmy@pobox.com](mailto:pygmy@pobox.com) a fairly stable address. Currently, any mail sent to [pygmy@pobox.com](mailto:pygmy@pobox.com) is merely forwarded to my "real" account: [sergeant@axiom.net](mailto:sergeant@axiom.net). I never know how long I'll keep Axiom.

I had set things up with a program running in my directory on Axiom's computer to collect a few newsgroups and collect my incoming email, zip it all up, and download it to my pc. Then, off-line, I would read and reply to newsgroups and email using the program Yarn, running on the pc. Yarn produced a zip file which another program running on Axiom would upload, unzip, and mail or post. This was working fairly well until Axiom stopped keeping the newsgroup files on its own machine. Instead, Axiom contracted with another provider to supply remote news access. This was a disappointment to me, as the programs I was running on Axiom cannot handle the remote news server. There may be a way around it, but I haven't found it. I still use those programs to download and upload email messages, but now I use similar programs running on Eskimo to collect and post my newsgroup messages. I still need Axiom to give me the local phone call that allows me to access Eskimo.

I can read news on-line via Axiom if I bring up the Windows software to do so. I don't like this as much as reading news off-line. Off-line, in Yarn, as soon as I press a key the requested action happens, such as moving to the next article. Reading news on-line requires putting up with an annoying delay. From a human factors standpoint, I think waiting on a computer rots your brain and eats away your soul. If I can ever figure out whether I'll be in school for the next year, I might drop Axiom altogether and use my SWT account to access Eskimo for both newsgroups and email. In that case, I'll have Pobox forward mail to my Eskimo account. We really do have three ISPs in my little town of San Marcos,

not counting SWT. I am still amazed.

I'm using a Web browser more and more, and using ftp less. For file transfers, it is very convenient to click on the file to be downloaded. I usually use a text-only Web browser named lynx. You probably have it on your system, too, if you have a shell account with your ISP. You can see my Web page by typing

lynx <http://www.eskimo.com/~pygmy>

or by plugging in the address at the right place in Netscape or whatever other browser you are using. I'm usually not interested in seeing pictures when I use a Web browser, so lynx has been fairly convenient for me, but I'm beginning to use a graphical browser more often. Even then, I usually turn off the pictures so the browser will run faster.

Among other things on my web site, I have various Forth links, a few jokes, and a picture of myself as an innocent child.

Various means of searching have evolved in response to the enormous amount of data on the internet. Lycos, Yahoo, Dejanews, and other web sites allow you to search for documents and people. Have you lost someone's email address? Perhaps he has posted something containing his new address to a newsgroup. Dejanews might help with that. I won't go into the details of how you use them. Just jump in with your browser and follow various links and read various documents until you find what you are looking for. My Web page has links to a few such sites.

I do question whether I can justify Axiom's monthly cost of \$30 + tax (for up 150 hours per month — I use about 30). Are any of you getting email via a BBS or FIDOnet, etc.? How is that working out?

### It's a GUI World

I always thought "graphics" meant "writing," so I stay somewhat concerned about the term Graphical User Interface. Nevertheless, today it means a display on a computer monitor that is more involved than a mere fixed-font text-based display. I certainly see the need for pictures and drawings on a computer. What I fail to understand is why anyone would consider proportional fonts and tiny fonts to be an improvement. I guess it came about because of the idea of

WYSIWYG (what you see is what you get) plus accepting poorly drawn characters in return for allowing pictures on the screen at the same time as text. Am I the only one who hasn't invested in a super duper monitor? (As it is, mine does have a .28 mm dot pitch, so it isn't the very worst monitor I've ever seen.) I can understand the desire for WYSIWYG when you are laying out a newspaper or a printed circuit board. For ordinary text, I think it is a hindrance. Of course, you don't really get what you see and you don't really see what you get. Several times I've missed spotting an unwanted space character that crept into a document between the last printable character of the sentence and the period because the proportional font 'space' is so narrow. What might be better than WYSIWYG is WYWIWYG (what you want is what you get).

### J and Forth Conferences

I notice that J (the APL-like language I mentioned in my previous article) is having a conference in Toronto on June 24-25, 1996. This is just after the Rochester Forth Conference in Toronto June 19-22. I think it would be great fun to attend both and contrast the different cultures and approaches to software development. I don't think I'll get to either conference this year, but if you do, please write to tell all about them.

### Linux

I mentioned in my previous article that a Linux CD ROM could be had from Daniel Jimenez for \$ 10 plus \$3 shipping. That still doesn't sound bad. Splurging, though, I bought the InfoMagic 5-CD Developer's Resource set. This includes several Linux distributions, including a version of Slackware newer than the one I got from Jimenez, and lots and lots of other material related to Linux. I haven't had time to go through all of it yet. I ordered it via email late at night on January 17 and received it on January 20. The cost, including shipping, was \$30. So, my experience with InfoMagic has been positive. But, not everyone has been happy with them! Ed Ngai had a very unpleasant experience with their technical support line and summarizes it as "I spent \$44.00 for 22 min. of nonsense tech, support."

Ed eventually figured out what he needed without InfoMagic's help. There is a quick summary of how he partitioned a 1.6GB SCSI drive to work with Linux in the table.

```

C:\ = 10M, D:\ = 50M . E:\ = 100M , Linux Swap = 30M
Linux 1st Native Partition = placed below the 1024th cylinder
Linux 2nd Native Partition = the remaining hard drive.
Disk /dev/sda: 64 heads, 32 sectors, 1665 cylinders
Units = cylinders of 2048 * 512 bytes

```

Device	Booꝑ	Begin	Start	End	Blocks	Id	System
/dev/sda1		1	1	11	11248	1	DOS 12-bit FAT
/dev/sda2		12	12	1665	1693696	5	Extended
/dev/sda5		12	12	62	52208	6	DOS 16-bit >=32M
/dev/sda6		63	63	163	103408	6	DOS 16-bit >=32M
/dev/sda7		164	164	194	31728	82	Linux swap
/dev/sda8		195	195	1023	848880	83	Linux native
/dev/sda9		1024	1024	1665	657392	83	Linux native
"basically	...	yes! you	can run	11 nux	from a	logi ca1	parti ti on."

Speaking of documentation and technical support, did anyone get a copy of Russ Walter's Secret Guide to Computers that I recommended? Did you enjoy it? Also, did I mention that I think the Linux CDs (and the Linux and other documents on the internet) are a useful source of hardware information about the IBM PC? All of these alternative operating systems need to interact with the hardware. If they don't use DOS or BIOS calls to do the work, then they need to have their own routines. So, keep Minix, Linux, FreeBSD, NetBSD, MMURTL., and maybe Oberon in mind when you need to figure out how to interface to the PC hardware.

### Tradeoffs

There are tradeoffs everywhere we look. I recently studied some famous string searching algorithms (in a course at SWT). The point that impressed me the most was most of the speed up comes from simple improvements to the naive algorithm. After that, a great deal of extra complexity does speed the search up some, but relatively little. That final extra bit of speed could cost a lot of programmer time. Depending on the application, that extra programmer time might never be recovered. (I shuddered to think of the man-years spent developing those algorithms. Who paid for that? If it was a labor of love, then no problem. However, I suspect a good bit of our tax money went into it.)

One tradeoff often overlooked is that of "cognitive burden." As the software world gets further from Keep It Simple, the cognitive burden seems to increase. A typewriter was straightforward. You could see how it operated. Now we have Word Perfect and Microsoft Word and they are harder to learn and harder to deal with (that's what I mean by cognitive burden). Even if there is a net gain to the end user, increased complexity surely places a burden upon the programmer. I am thinking now of these great software libraries. You can buy a communications library, a database library, and on and on. I am becoming suspicious that the cognitive burden of dealing with the tremendous complexity of the libraries is too much. Perhaps it would be cheaper to write the routines yourself, that you really need, than to look up and understand and learn to use the canned library routines. This is part of why I am in favor of small, simple Forths — small enough that you can understand them completely. More is not always better.

## Tcl/Tk

I've been playing some with Tcl/Tk, a string-based scripting language and its companion set of GUI widgets for building windowed applications. The internet is filled with information about Tcl/Tk so I won't try to write another tutorial. I'll just tell you my first reactions.

One of its strong points, perhaps its main point, is the promise of platform independence. Its applications are supposed to run on Windows, Unix, and the Mac with essentially the same source code. I don't know about the Mac, but I think it really only runs well under Unix. It runs under Windows, but there are little annoying things, such as the screen blacking out when you try to execute a system command. There may be ways around this or it may be fixed in the future. John Ousterhout, previously at Berkeley, is the force behind it. Now that John has moved to Sun, Tcl/Tk now has corporate support as well, so I expect it to continue to improve. As I see it today, you get platform independence as long as the only platform you use is Unix.

Another touted feature is how easily it can be extended with C routines, or how easily it can be embedded in a C program. This lets you write your workhorse routines in the faster C language, but co-ordinate them with the more comfortable, convenient, interactive Tcl. This makes sense, yet I believe we have the same ability even more conveniently with Forth. I have just illustrated one way to do this with Pygmy in my article "Coordinating Pygmy and C" that appeared in the March/April 1996 issue of Forth Dimensions (Vol XVII, No 6). Sample code showing how to call C library graphics routines from Pygmy appears in the article and also on my Web page. It just seems to me that Tcl works too damn hard at doing something that should be much easier. It is supposed to have simple syntax. I find its syntax regular, but awkward. It takes a good bit of work (and perhaps reading several books) to get up to speed on it. Perhaps it earns its keep when developing X windows applications on Unix (where Tcl runs a little more smoothly), but I suspect you'd be better off with Borland C/C++ or Delphi or Forth or J if you are developing just for Windows.

Tcl does have a thorough set of list and string handling functions, the usual C-like control functions, and associative arrays, so it may not be as bleak as I make it sound above. Once you get the hang of it, it is fairly easy to put up windows, pick lists, check boxes, buttons, sliders, scroll-bars, and so forth. It is a bit tricky learning how to position these items just where you want them. Tcl/Tk is free and has lots of add-on packages, but many of these require you to recompile Tcl.

## Forth Questions and Answers

I occasionally get questions about Pygmy. I've collected a few recent ones here along with my answers.

Q. In Pygmy, is there a place that explains what the stack comment abbreviations are (like what n is, etc)?

A. Here are some common abbreviations I use

n	16-bit signed number
u	16-bit unsigned number
#	usually means a count
a	address
f	usually means a flag

I like simple stack comments that don't have too much clutter. I write the stack comment for CMOVE, which takes a from address, a to address, and a count as ( from to # -). The inputs are to the left of the hyphen and the outputs to the right. In the example for CMOVE, there are no outputs, but I still put the hyphen, so I don't have to remember whether the items are inputs or outputs.

Q. What are DEFER'd words?

A. A DEFER'd word gives an extra level of indirection to make it easy to redefine the action of a word later. For example, EMIT makes a good candidate for a DEFER'd word. Most of the time we want EMIT to print to the screen, but sometimes we want it to print to the printer or a disk file or whatever. So, the word (EMIT does the real work when we print to the screen and (PEMIT (or whatever) does the real work when we print to the printer. Outside a colon definition we alter which word EMIT will execute by typing something like

```
• (EMIT IS EMIT
```

Inside a definition we alter it with something like

```
:>PRN (-) [ ] (PEMIT IS EMIT ;  
:>SCR (-) [ ] (EMIT IS EMIT ;
```

Q. I was looking for the definition of EMIT and got no further than scr #45 which told me that this was a DEFER'd word?

A. The easy way to track down a word that is currently in the dictionary, such as EMIT, is to type

```
V EMIT
```

to pop you into the editor at the word's definition. This shows that EMIT is a DEFER'd word. Then, to see what word EMIT is pointing to, type

```
SEE EMIT
```

which probably says (EMIT. Then you could type

```
V (EMIT
```

to see the definition of (EMIT.

Q. How can I disable ok from appearing in cases where, for cosmetic reasons, it is undesirable?

A. What I do in these cases is to add KEY DROP to my code. That makes the display wait until I press a key before returning to the OK prompt.

## The Big Question

Q. What can I do if my data won't fit into the 64KB segment available to Pygmy? I have a large amount of static data to contend with, mostly 64-bit floats, and not all of it is amenable to being put in some structure on the heap. Basically what I'm doing can involve several megabytes of data.

A. Let's look into this a piece at a time. The 64KB segment into which Pygmy's dictionary must fit can contain a `_lot_` of source code, so the desire to have a larger address space usually comes about from problems of data storage rather than of code storage. So, if we could just put the data somewhere else, a small Forth wouldn't seem so limiting after all.

We will start with a simple example of how to handle an array of 16-bit integers. If the array is small enough, the most convenient solution is simply to put it into the dictionary. We will do this first and then consider how to modify the code to put the array on disk and still have the very same convenient access to it as if it were in the dictionary.

Since we might want to define more than one array of integers, let's write a defining word to create such an array:

```
: ARRAY ( u - ) ( u - a )
  CREATE ( u ) CELLS ALLOT
  DOES> ( u a ) SWAP CELLS + ;
```

The first thing you might notice is that `ARRAY` has two stack comments. The first shows what happens when `ARRAY` executes. The second shows what happens when a word defined by `ARRAY` executes. In our example, we will use `ARRAY` to define an array named `MARCH-SALES`. The first stack comment tells us that when we define `MARCH-SALES` we must pass to `ARRAY` the number of elements the array should contain. The second stack comment tells us that when we execute `MARCH-SALES` we must pass to it the number of the element we want to access and that the result will be the address of that element. Note that the additional stack comment right after `DOES>` indicates a count and an address are on the stack. Where does the address come from? When the child of `ARRAY` executes, the caller put the count on the stack and, because it is a `DOES>` word, the runtime portion of `DOES>` puts the address of the child's parameter field on the stack automatically. This address is the address of the beginning of the array. To point to the requested slot in the array, we must add the correct offset (i.e. the number of the desired item times the length of each item). That's what the `SWAP CELLS +` does.

This first version does no error checking. It depends upon the word `CELLS` to convert a count of integers into the corresponding count of bytes. In a 16-bit Forth such as Pygmy, it could be defined as

```
: CELLS ( cells - bytes ) 2* ;
```

Once `ARRAY` has been defined, we can use it to define an array named `MARCH-SALES` which will have 31 slots,

each slot holding the count of how many lemonades were sold on that day,

```
32 ARRAY MARCH-SALES
```

When the word `MARCH-SALES` is executed, it returns the address of the slot for a particular day. The array is zero based, although we could change the definition of `ARRAY` to make it one based. For now, we will leave it zero based and just waste the zero cell. That is why we declare `MARCH-SALES` to have 32 slots instead of the 31 slots a calendar might suggest. Suppose we want to change the count stored for March 3rd to 75:

```
75 3 MARCH-SALES !
```

Suppose we want to get the count stored for March 17th:

```
17 MARCH-SALES @
```

This method of handling the array is very simple and easy to follow. It also makes processing the array in a loop easy to do. The following would print a report of the counts for each day in March:

```
: .REPORT ( - )
  CR ." Number of Sales per Day during March, 1996"
  CR
  CR . " Day Count"
  0 31 FOR 1+ ( day )
    CR DUP 5 .R 4 SPACES DUP 5 .R
  NEXT ( day ) DROP ( ) ;
```

The `5 .R` prints the number right justified in a 5-character field—to make the report line up nicely.

If we only had this one short array, we would just keep it in the dictionary. But, nevertheless, we will use it as a very simple example of how to move the array to disk so it doesn't take up space in the dictionary. After we change `MARCH-SALES` to reside on disk, it should be interesting to see how we must change our `_use_` of `MARCH-SALES` so it can work from disk.

To store the array on disk, we take advantage of Forth's built-in virtual memory, via the word `BLOCK`. `BLOCK` is given the requested block number, loads the block from disk into a disk buffer (if it is not already in a disk buffer), and returns the address in memory of the disk buffer.

Suppose we find that we have block 2017 available in `YOURFILE.SCR` and that the file is automatically opened when Pygmy starts up. Merely by saying 2017 `BLOCK` we get the address in memory of the data on that block. How convenient! Since we only have 32 16-bit integers in the array, we only need to store 64 bytes on the disk. We could rewrite the defining word as

```
: ARRAY ( u - ) ( U - a )
  CREATE ( u ) DROP
  DOES> ( u a ) DROP CELLS 2017 BLOCK + ;
```

Note in this particular case we do not need to tell `ARRAY` how many items will be in the array. We could have changed the first stack comment to `(-)`. Instead, I want to keep the stack comments for `ARRAY` exactly as they were in the first

version of ARRAY (the one that kept the array in the dictionary). So, when ARRAY executes, it simply DROPS the number of elements. By keeping the stack comments exactly the same, the definition of ARRAY is the `_only_` change we must make! We change that definition then reload our code and the definitions of MARCH-SALES and of .REPORT do not need to change at all. So, the use of the array is exactly the same, whether it is on disk or in the dictionary! (The only exception is UPDATE discussed below.)

I'd better point out that this most recent definition of ARRAY has two serious limitations! First, we have taken advantage of the fact that the entire array (64 bytes) will fit within a single disk block (1024 bytes). The second limitation is that the starting block number (2017 in the example) is hard coded. Thus, we'd better not define more than one array, or they would conflict with each other. Let's fix the second problem first by passing a starting block number to ARRAY instead of a count (since we aren't really using the count anyway):

```
: ARRAY ( starting - block - ) ( u - a )
  CREATE ( starting-block )
  DOES> ( u a ) @ SLOCK SWAP CELLS + ;
```

We save the starting block number when ARRAY executes by 'comma'ing it into the child's parameter field. Then, when the child executes, the first thing it does is fetch the starting block number. This requires us to change how we define MARCH-SALES to

```
2017 ARRAY MARCH-SALES
```

but allows us to define additional arrays that won't conflict with each other, such as

```
2018 ARRAY APRIL-SALES
2019 ARRAY MAY-SALES
```

supposing, of course, that blocks 2018 and 2019 exist and are available for our use.

Next, we tackle the problem of how to allow the array to span more than one block. This is a simple extension of what we have so far. Instead of just adding an offset to the beginning of a block buffer, we must calculate a two-part offset. The first part is how many blocks deep the element we want is located. The second part is the usual byte offset we used previously.

```
: ARRAY ( start!ng - block - ) ( u - a )
  CREATE ( starting-block )
  DOES> ( u a )
    SWAP CELLS 1024 U/MOD ( a rem quot )
    ROT @ + BLOCK ( rem a ) + ;
```

First we find the total offset in bytes to reach the element we want with SWAP CELLS then we divide this number of bytes by 1024 (the number of bytes per block) with U/MOD. This produces a remainder and a quotient. The quotient is the number of full blocks we must add to the starting block to get to the block containing the element. Then we add the remainder to get the actual address inside the block buffer. A minor point is that instead of dividing the number of bytes

by 1024 we could have divided the number of elements by the number of elements that fit on a single block. In other words, it doesn't make any difference whether we divide the number of bytes by 1024 or the number of cells by 512, as long as all the numbers involved are small enough to fit into a 16-bit integer. If we have more than about 32000 elements in the array, we'd prefer to divide cells by 512. In that case, we'd have to consider whether the remainder represented cells or bytes. So, the equivalent definition would be

```
: ARRAY ( start!ng - block - ) ( u - a )
  CREATE ( starting-block )
  DOES> ( u a )
    SWAP 512 U/MOD ( a rem quot )
    ROT @ + BLOCK ( rem a ) SWAP CELLS + ;
```

In the several disk versions we've assumed we had a block file open with space available on it for our arrays. You might need to create a file of the correct size and open it in the right place. One of the easiest ways is to copy an existing block file at the DOS level and then open it in Pygmy and extend it to the desired size in the editor with the F9 key. Suppose you want two very large arrays, each holding nearly half a million integers. You could create two files, perhaps ARRAY1.BLK and ARRAY2.BLK as just described, containing 1000 blocks each. Then, you could open the files and declare two arrays like this:

```
" ARRAY1.BLK" '6 OPEN
" ARRAY2.BLK" '7 OPEN
```

```
6000 ARRAY COUNTS
7000 ARRAY PRICES
```

to devote all 1000 blocks in ARRAY1.BLK to the COUNTS array and all 1000 blocks in ARRAY2.BLK to the PRICES array.

We haven't done anything about range checking. I would ordinarily just try to guarantee that the children of ARRAY were never passed an out of range element, rather than trying to catch it with a runtime check. But, your approach to error handling might differ, so we could store the number of elements allowed and do a runtime check to be sure the requested element is in the proper range.

One point is that you have a lot of flexibility to handle the data storage exactly the way you wish. Another point, is that the rest of the code can be used essentially unchanged regardless of whether you store the data in the dictionary, in a fixed place in a single block, or in a range of blocks. (The only change needed is discussed later — see UPDATE.) These days many disk controllers have built-in cache RAM and often the OS will cache the disk data also. All of this is in addition to the control you have of how many Forth disk buffers you set up. Because of this, you might neither see the disk activity nor take the performance hit you might expect by storing the data on disk.

The above examples assumed each array element was 16-bits wide. It is just as easy to setup arrays of elements of any size up to 1024 bytes wide. Suppose we had the words F@, F!, F+ etc to fetch and store and add 8-byte wide floating

point numbers. We could define an array of floats to reside on disk as

```
: FARRAY ( starting-block -) ( u - a)
  CREATE ( starting-block)
  DOES> ( u a)
    SWAP 128 U/MOD ( 'a rem quot)
    ROT @ + BLOCK ( rem a) SWAP 8 * + ;
```

We could go one step further and define a two dimensional array of floats. In this case we need to specify how many elements are in each row.

```
: 2FARRAY ( starting - block width -)
  ( row column - a)
  CREATE ( starting-block width)
  DOES> ( r c a)
    DUP 2 + @ PUSH ( save starting block)
    ( r c a) @ ( r c width) ROT * +
    ( element) 128 U/MOD ( rem quot)
    POP + BLOCK ( rem a) SWAP 8 * + ;
```

Now we could define MILLIBARS as a 2-dimensional array of air-pressure readings on a 50x50 grid.

```
7000 50 2FARRAY MILLIBARS
```

and then get the value of element row=17, column=30 with

```
17 30 MILLIBARS F@
```

Note, when the data reside on disk, you must use the word UPDATE after changing any element so the disk buffer will be marked as needing to be saved back to disk. Thus, the example of

```
75 3 MARCH-SALES !
```

would become

```
75 3 MARCH-SALES ! UPDATE
```

Disclaimer: the code is untested. Check it out if you use it, and please send me any corrections. It should give you a starting point for handling large amounts of data with a small Forth.

#### Contact info:

Eskimo North [info@eskimo.com](mailto:info@eskimo.com)

Forth Interest Group  
(510) 893-6784  
<http://www.forth.org/fig.html>

J and its conference:  
Anne Faust (612)470-7345 [amfaust@aol.com](mailto:amfaust@aol.com)  
<http://www.jsoftware.com>

Linux  
Daniel Jimenez  
[adras@crl.com](mailto:adras@crl.com)  
InfoMagic

(800) 800-6613, (520) 526-9565  
[info@infomagic.com](mailto:info@infomagic.com)  
<http://www.infomagic.com>

Pobox [info@pobox.com](mailto:info@pobox.com)

Rochester Forth Conference:  
Larry Forsley (716) 235-0168  
<http://maccs.dcss.mcmaster.ca/~ns/96roch.html>

Russ Walter (617) 666-2666

#### Reader to Reader - continued from Page 4

Limit Time
250,000 168
500,000 441

Dave Baldwin entered my code and compiled it with Borland Turbo C 3.1 and had the compiler generate 386 object code. He ran it on a 486-DX/33 and reported times:

Limit Time
250,000 4.67
500,000 11.04
1,000,000 27.36

Dave correctly deduced that my compiler had generated 286 code. I replied that my Turbo C 3.0 could not generate 386 code. I re-ran my program (in 286 code) on my 486-100 DX/4 system and times were:

Limit Time
250,000 17.7
500,000 48.5
1,000,000 125.2

Today at work I compiled the program for these three limits with Borland C++ 4.5 set to generate 486 code, and to optimize for speed, not code size. Times on my 486-100 DX/4 were:

Limit time
250,000 1.49
500,000 3.62
1,000,000 8.90

These are obviously about eleven times faster than the same computer running 286 code. I had stuck with Turbo C 3.0 since that was the last version that could be run under DOS. 4.0 and 4.5 run only under Windows (UGH). They both still can generate object code that runs under DOS. Such is the price of progress. Since the article was written, my "current computer" ran the program about 53 times faster (thanks of course to the suggestions of the others).

Ron Anderson [rwilanders@provide.net](mailto:rwilanders@provide.net)

# Simplex III

by Dave Brooks

Special Feature

Advanced

TTL Computer

## Simplex-III: A home designed computer

This series of articles describes the design and construction of "Simplex-III", a home-built CPU, using TTL parts. After two false starts in the early 1970's, the final machine was built over the period 1975 - 1977. Testing resources were minimal: I was occasionally able to borrow a 20MHz oscilloscope, and I had a multimeter and a home-made logic probe. That was all. This was the reason for the very thorough monitoring of internal states: it is possible to step the machine one clock at a time, and see the effect on (almost) every internal flipflop at each step. Rather like modern boundary-scan testing.

The principal features are summarised in Table 1.

The entire CPU fitted into 109 TTL/MSI parts, including monitoring functions.

The machine still exists, and was recently run-up for the first time in a dozen years. Amazingly, it still worked.

The necessary design trade-offs are described, and also how the machine was built and operated. It is not intended to provide full constructional details. In any event, the machine was hand-wired; it did not use tracked circuit boards. In those days, personal CAD software (and indeed the personal computer) was unknown, and it would not have been worthwhile to lay out a set of boards by hand, for a one-off project.

## Background

It all began in 1968, when I was at University in Bangor, N. Wales. The entire campus possessed just two machines (Elliott 803 and Elliott 4130), each of which filled a large room. Students punched their own programs (usually in Algol) on cards or 5-track paper tape, and submitted them to the operators. This whetted my appetite for computing.

When I left University, I lost access to a computer, and gradually developed the idea of building my own. There was a free-floating community of computer experimenters in the UK at that time. We made do with what could be found, and no two people's machines bore the least likeness to each other. Designs invariably were conditioned by what hardware we could lay our hands on. In those days, even basic 7400 logic parts were almost unobtainable by amateurs in the UK. DRAMs and EPROMs did not exist.

TABLE 1.

Principal features:	
Data paths:	8 bits wide
Operand size:	1 to 8 bytes
Address space:	64k
Machine cycle:	1.68uS
Typical instruction:	8 cycles (13.5uS)

## Simplex-I

I was fortunate enough to get hold of bits of some wrecked hardware from the early 1960's: logic boards from an old IBM mainframe, and most of a non-functioning VERDAN computer (that's a tale in itself: a military hybrid digital/analogue unit - used in SINS - Ships Inertial Navigation System). Both of these used discrete transistors, with one board roughly equivalent to an SSI package of today. There was also a disk memory unit for VERDAN: 2048 words of 26 bits each. Yes, this was a disk, with a separate head-pair for each track. The read-head was one sector's length before the write, so that a bit-serial CPU with a 1-word latency could do read-modify-writes to a single word on disk. That disk also implemented most of the VERDAN CPU registers, using a purely 1950's technique called "revolvers": a write head precedes a read head, so that the segment of track between implements a shift register. Several such registers may exist on a single disk track. The system clock was generated from a pre-recorded disk track, so that the entire system synchronised to the disk.

Design principles for my project derived largely from Booth's "Automatic Digital Calculators" - 1951 or thereabouts. Booth and his co-workers were building with vacuum tubes: the book is a mine of ideas on how to use as few gates as possible.

Having acquired a motor-generator to produce the power for the disk motor (115 V, 400Hz 3-phase), I could start to run this thing up. A typical VERDAN PCB was a 8-bit shift register, so these were used unaltered. The architecture was pure 1950's: 7 serial "accumulators" (in the terminology of the time), and 2048 24-bit words of memory.

This project was later dubbed Simplex-I. It had reached the stage of having a working bit-serial arithmetic unit, when new vistas opened up.

### Simplex-II

Having moved to London, I was able to obtain scrap hardware containing 7400 TTL chips. A London surplus dealer had a bin full of logic modules which he knew nothing about (and hence would sell for a song), but which I realised had been built at the place where I worked. So I had access to the manuals. Another surplus store provided a "no details" 4096 x 12-bit core memory array, and Simplex-II was under way. This was to be a virtual clone of a Digital Equipment Corporation PDP-8/S (for which I even had some software).

IO was a World War II surplus teletype machine (all of 7.5 chars/second).

### Simplex-III

In late 1974, when Simplex-II was well along, I moved to Australia and the rules changed again. 7400 chips were now available at acceptable prices (via surplus dealers in the USA), and the first (1k bit) DRAM and EPROM chips were reaching the amateur market. Now I had spent my last 3 years in the UK working with the GEC 2050, at an engineering and assembly-code level, so I knew it thoroughly (including a collection of useful software techniques). Consequently Simplex-III was modelled on the 2050.

It was now 1976, and the 8080 CPU was selling at \$180. I thought long and hard, whether to use an 8080 anyway, but realised the cost would be little different, and a much better learning experience to do it myself. In those days, the only minicomputer (not micro) to use a stack was the PDP-11, of which I had no experience. So I stuck with the architecture I knew. The use of stacks as a subroutine linkage device was quite rare in those days also, most stacks were used as a data-handling device in compilers, and those were routinely emulated in software.

Naturally, there was considerable input from various friends during the design phase, not least in the form of a "wish list". Many of them saw themselves as potential users of the machine, once it was built. One of those friends was into astronomy, and indicated he would like to do a lot of maths on very large numbers. Largely for him, Simplex-III included arithmetic on integers up to 64 bits. There was never any intention to provide hardware floating-point maths.

The object was to provide much of the GEC 2050's functionality, with far less cost. I dumped the 2050's elaborate IO system (it had an in-built 64-channel DMA) and left everything memory mapped. The interrupt system again was vastly cut down, owing more to the Elliott 903 (another vintage machine, using discrete transistors). In those days, no-one believed you could ever run out of 64kB main memory.

Simplex-III was based around TTL/MSI logic, and 1kb DRAMs. A design goal was to fit the microcode into two 32-byte bipolar PROMs. In the event, a PROM programmer was not available, so the PROMs were simulated by a discrete diode matrix, which connected to the PROM sockets.

The machine was built in a home-made case, approximately 380 x 200 x 200mm, including power supply and space for expansion cards.

The following articles will describe the machine architecture, instruction set, debugging facilities, and finally a look at the detailed logic operations.

Ed. - *Here's a blurb about Dave's company and the Z182 board he has available.*

D-X DESIGNS PTY LTD  
7 Buchan Close  
SPEARWOOD  
Western Australia 6163  
Tel/fax: +61 9 434 4280  
Email: [daveb@inet.net.au](mailto:daveb@inet.net.au)  
Web page: <http://www.inetnet.au/~daveb>

With over 25 years digital design experience, D-X Designs Pty Ltd provides a custom design service for digital equipment: We specialise in embedded applications, with experience in 8051, 8085, Z-80 and 80186 processors. Software capability includes Assembler, Pascal, Fortran C and C++. Our second speciality is design for Xilinx FPGAs, for which we have a full tool-set.

#### Z80182 8-BIT CPU BOARD ("P112")

What is it?

It provides a Z80182 (Z-80 upgrade) CPU with up to 1MB of memory, serial, parallel and diskette IO, and realtime clock, in a 3.5-inch drive form factor. Powered solely from 5V, it draws 150mA (nominal: not including disk drives).

1. Dimensions: 130 x 100mm (5.1 x 3.9 inch)
2. Support for 5.25 and 3.5 inch diskette drives (up to 4 drives, mixed types)
3. Z80182 CPU at 16MHz (12.288, 18.432 or 24.576MHz optional)
4. 32kB flash ROM, in-board reprogrammable
5. 64kB SRAM, upgradeable to 1MB
6. Real-time clock/RAM, with on-board battery
7. 5 (yes, five) serial IO ports, 2 as PC-AT compatible connectors, 3 as TTL outputs
8. Parallel port, IBM compatible, with bidirectional ability 5
9. Bus expansion/logic analyser socket
10. Software included:
  - Shareware DOS+ and CCP+ (replace CP/M)
  - Shareware PPIP (replaces PIP)
  - Shareware UUENCODE & UUDECODE
  - BIOS support for diskettes, parallel & RS232 serial ports
  - ROM monitor, including debugger
  - Utilities:
    - ASCII file-transfer (eg UUENCODEd)
    - Disk format
    - In-system flash-ROM reprogrammer
    - Real-time clock sample code
    - All source files
    - All code (except the shareware items) is offered under the GNU General Public License.

# TCJ Center Fold? amr552LC and 8031 Core

Special Feature

All Users

80C552 & 8031

The TCJ Centerfold is usually for older computer stuff, right? Well, the 8051 is only a couple of years younger than the Z80. It was designed as a successor to the 8048 series. It had an 'improved' instruction set, a built-in serial port, and could address much more memory.

By the end of the eighties, many variations of the basic 8051 had been introduced. Now there's several hundred and those who can afford it can get their own versions made.

From the 8051 FAQ by Russ Hersch, some of the major manufacturers are:

- AMD Enhanced 8051 parts (no longer producing 80x51 parts)
- Atmel FLASH and semi-custom parts
- Dallas Battery backed, program download, and fastest variants
- Intel 8051 through 80c51gb / 80c51sl
- Matra 80c154, low voltage static variants
- OKI 80c154, mask parts
- Philips 87c748 thru 89c588 - more variants than anyone else
- Siemens 80c501 through 80c517a, and SIECO cores
- SMC COM20051 with ARCNET token bus network engine
- SSI 80x52, 2 x HDLC variant for MODEM use

The 8051 FAQ is available on the TCJ Web pages and on the TCJ/DIBs BBS. The TCJ/DIBs BBS also has many files from the Phillips and Intel BBS's.

Intel has introduced the 8x151 and 8x251 variants also. These are supposedly code compatible with the original 8051, but there's a catch. Even with the ROM-less parts, you have to have access to an Eprom programmer that will allow you to set configuration bits before you can drop them in in place of an 8051/31.

8051's and it's descendents are used by the truckload at times. I was in a telephone switching center that had an 8032 on virtually every one of the thousands of plugin cards. They were used for the low level control of each one of the line cards in the system.

The center of the Centerfold is the schematic of the amr552LC from AM Research. It's based on the 80C552, a variation of the 8051 that's produced by Phillips. Al Mitchell, the 'AM' before the 'Research', has included a special offer for TCJ readers.

On the last page of the Centerfold, is my 8031 Core schematic. I use this as the starting point for my 8031 designs. It's 4% chips. If the internal ram is enough, you can eliminate the 6264 and the 74HC00 and use only 3 chips which I've done a couple of times. For an RS-232 interface, the MAX232 shown on Al's schematic is an excellent solution. The 8031 doesn't have any handshaking lines as such for it's serial port. If you want or need them, you have to use some of the other port pins.

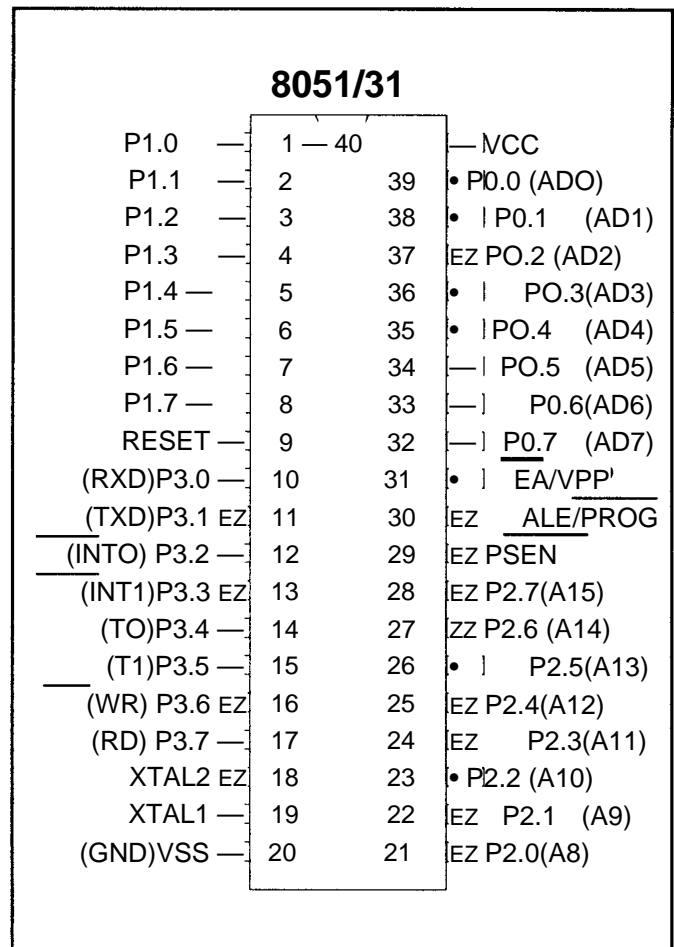



## The amr552LC Single Board Computer

The amr552LC SBC is one of a series based upon the venerable 8051. We elected to offer this hardware superset of the 8051 to TCJ readers to demonstrate just how much the embedded control industry has progressed since the 8051 was released in 1977. Over the years this microcontroller has consistently been our most popular SBC due to the many features and low cost.

Should anyone wish to prototype or wirewrap their own variant of the 8051 family then the following schematic will work just fine. All versions use Port 0 and 2 for external address and data busses so you can just pencil in your favorite version. We have other SBC's for most should you want to avoid the problem-prone wire-wrapping stage.

Note that every member of the 8051 family has an external pin labeled \*EA or "Not External Address." When tied low this pin tells the 8051 to look at external memory for program and data memory. When tied high program data is taken from the internal ROM if the variant has any.

The 8051 family has what is called a "Harvard" architecture. Harvard meaning that separate Program and Data spaces are used. These two distinct 64K blocks of memory are addressed by the \*PSEN signal in conjunction with \*RD and \*WR. In most every interpretative 8051 implementation these two memory spaces are overlaid. Rather than using a myriad of jumpers we have optimized the glue logic to implement this always. This means that not only our FORTH development environment but BASIC-51/2 will also run on our boards.

Further, two memory sockets have been implemented, one for RAM and one for ROM. Either an 8K or a 32K device may be installed in either location with only one jumper required to select the RAM size. Either ROM size fits the same socket without a jumper change.

Most of the SBC failures we've encountered were invariably due to incorrect power connections so we decided to install the regulator to isolate the CPU from wiring errors. Further we use a 2.1 mm coaxial connector to further minimize the confusion of first getting the system working. Also included is a MAX232 communications transceiver. Some SBC's do not use legal RS232 levels and therefore are limited in baud rate or distance they may communicate. The MAX232 uses charge pumps to generate a real  $\pm 10V$  from the +5V power supply. With this design our standard software can communicate at 19.2 Kbaud over reasonable distances.

The 80C552 controller chip used is made by Philips and the second-most powerful 8051 variant in existence. In addition to all the features of the 8051 it includes: two Pulse Width Modulator outputs, twice the onboard RAM, two extra 8-bit I/O ports, one of which can be a fast 8-input 10-bit A/D converter(!!!) three extra timers, one of which is a Watchdog timer, many timer/counters with invokable interrupts should you decide to use them, a timer prescaler and is very inexpensive.

The final hardware feature is not visible on the schematic, it is a 10 sq in prototyping area on our pcb ringed with both ground and +5v. +Unreg is nearby should it me required. The printed circuit board is 4" by 6", black with white silk screen.

The editor of TCJ has severely twisted our collective arms, and since Dave is bigger and uglier than we are, we have agreed to make the bare board, a complete kit and system available for TCJ readers at reduced prices of \$25/\$80/\$199.

A quick word about the system above: it includes not only an assembled pcb but all memory, cables, power supply and development software. The software includes a communications package so you can speak to the sbc from your PC, an integrated assembler, high level Forth compiler, full screen text editor with multiple file cut&paste capability, a large library of useful functions such as LCD's, keypads, editors, etc. and Frequently Asked Questions.

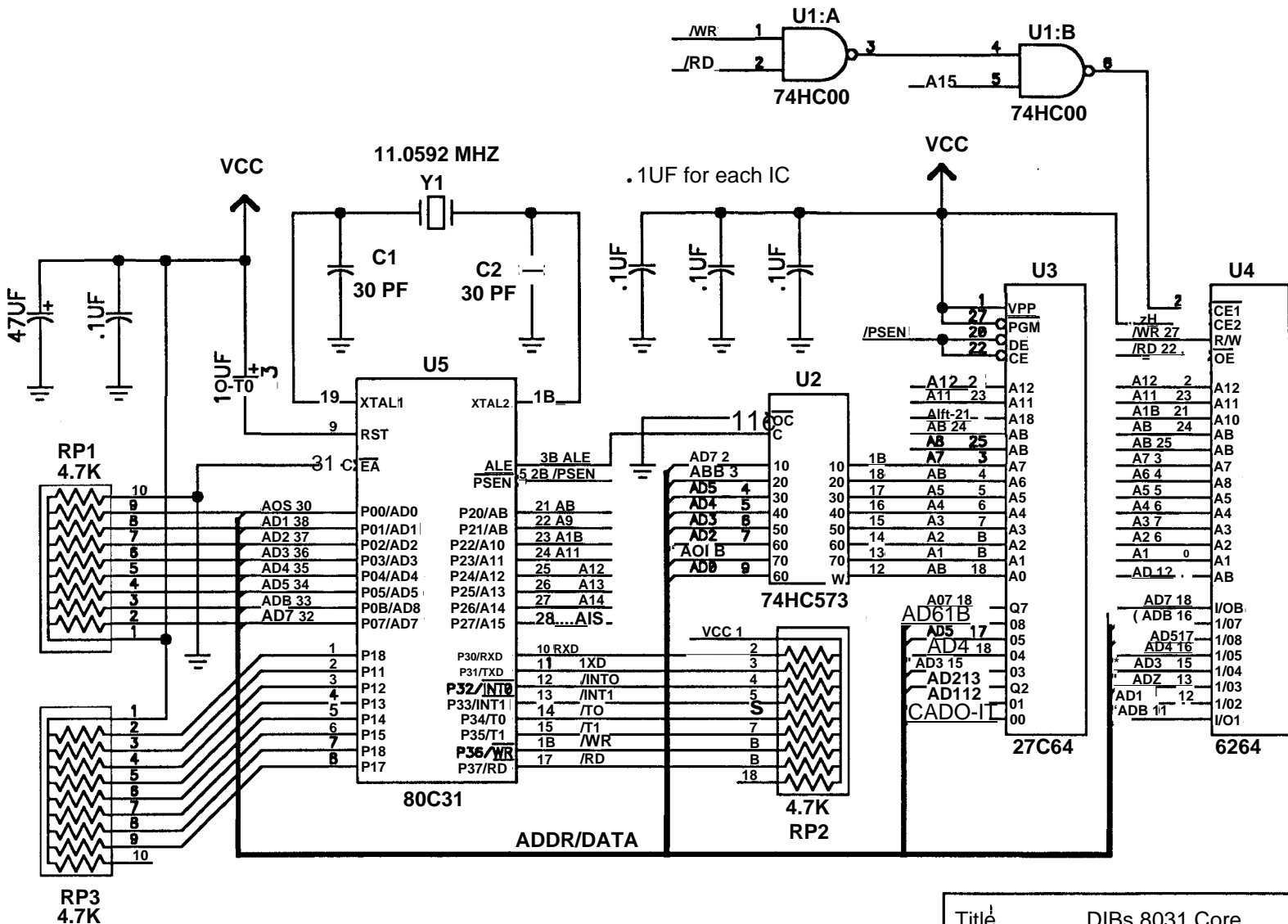

Title DIBs 8031 Core		
Size A	DIBs Electronic Design (916) 722-3877	Rev
Date Sun Jul 09 1995	Drawn by DIEIs	
Filename B031CORE.S01	Sheet 1 of 1	

---

---

# Dr. S-100

By Herb Johnson

Regular Feature

Intermediate

The Mail Bag

---

---

## The burdens of time

For once, I've been able to share my burden of "lawn care" with the rest of the country. Namely, the three feet of snow we've had in February with two feet coming down in a few days! But now, at the end of February, the wind is howling and the temperature is in the mid-50's, both events most unusual. With snow still on the ground, I'm trimming bushes and thinking of sod.

For this issue, I reach again into the mail file - very little postal or phone correspondence these days - and also acknowledge some questions and some received stuff.

My regrets, but I find my new second-shift job requires more time than I have without cutting back. In addition, my S-100 correspondence has declined in the last year or two, now mostly on the Internet. To do more S100 stuff than just answer my e-mail, to assimilate some of the systems I've received in the last year, and to do more astronomy, I've decided to put my "Dr. S-100" column on vacation for a few issues. And, with the first batch of GIDE controllers now sold and initial IDE software in development, I'm turning over US sales and support to Dave Baldwin of TCJ. But maybe I'll contribute an astronomical electronics article in the future!

I will of course take email and postal mail inquiries, and offer docs and hardware for modest costs. This issue, in fact, I show you the kind of correspondence I'm doing. But I must note that the trend is lower prices on S-100 stuff, not higher. This is not necessarily good, as it discourages efforts to save and distribute. That too is a burden of

time.

## Recent Acquisitions, help needed:

Keith M Address kindly donated a Big Board system and a selection of S-100 cards, in exchange for copying some 8-inch disks with software onto MS-DOS diskettes. As the 8-inch disks were single sided, single density, it was relatively simple.

From: Chris McDonough  
<[75027.2646@Compuserve.com](mailto:75027.2646@Compuserve.com)>  
Subject: RE: Wacky IBM mini/Xerox : WP wkstn/monitors/more forsale

The Bernoulli boxes we have here are several dual 10 Meg drive models. We however have no cartridges for them. I do not know if they are in functional order or not, as I have not had the time or inclination to mess with them much. If you care to, you are welcome to visit us on a weekday or weekend (I am at the office 24/7 it seems), and test them yourself.

I did visit and accepted the drives for a modest price. I now have several of these Bernoulli drives. However, I do not have any controllers for these, and only a few cartridges. Any one have docs, software, IBM XT controllers?

To: [jcustin@ml.cambrex.com](mailto:jcustin@ml.cambrex.com)  
Date: Mon, 18 Dec 1995 21:13:00 - 0500

I need documentation on the Monitor Dynamics HDC1016 hard disk controller which was an ST-506 technology card. I also need the software that went with it that interfaced the hard disk controller to CPM/80 v. 2.2. I think it was a BASIC program that invoked several COM programs.

*While I have some Monitor Dynamics cards, and perhaps a disk, I don't seem to have much documentation. I have been asked for this before, so I think I'll ask on the Internet and other sources for some docs. I'll review the disk and get back to you: figure several dollars for a 8-inch copy of the disk and postage.*

To: "THE ROCHE APPROACH 1609"  
<[JROCHE@FAB 10.intel.com](mailto:JROCHE@FAB 10.intel.com)>  
Subject: info on SORD CP/M 68K  
Date: Tue, 16 Jan 1996 22:04:27 - 0500

On Sun, 14 Jan 96  
<[JROCHE@FAB10.intel.com](mailto:JROCHE@FAB10.intel.com)>  
wrote:

\*> Hi there,  
\*> A friend of mine was asking about cp/m68k awhile back  
\*> and you replied with some suggestions and info which was great.  
\*> In addition i was wondering if you know if there is such a thing  
\*> as a cp/m68k emulator for msdos and if so where could it be got.

You might ask on comp.os.cpm about this. But, I doubt there is such an emulator. Emulating CP/M is easy enough, DOS 1.0 calls will do most of that. Emulating the 68K might be problematic. You might scan the Simtel CD-ROM's or related online archives for a 68K emulator, and see if someone included hooks for CP/M.

I now have a few 68K Compupro cards, and could someday in principle bring up CP/M 68K. Not highly likely...

*Let me know what you come up with.*

Maybe I'll ask in my Mar/Apr column.

To: [syoung@nucleus.com](mailto:syoung@nucleus.com) (syoung) |  
Subject: Re: Possible CP/M machine?  
Date: Thu, 18 Jan 1996 21:33:05 -  
0500

You wrote:

I have run across, and subsequently acquired, a rather old machine that doesn't work at the moment, although I think I can get it working. What I'm wondering is, does this look like a CP/M machine to you. Here is the description (the reason I wonder is because the date on the side is of the CP/M era)..

It could be, maybe not. Check the boards themselves for information that is ETCHED into the board as copper: a manufacturer, model number, etc. Check the chips for date codes: 8512 would be the 12th week of 1985, that sort of thing. Describe the bus connectors: how many pins, how far apart are they (.1 inch, .125 inch, or what?). See if the INSIDE of the box or cover has any info. Let me know.

From: Eric Magnus  
<[eisley@sfsu.edu](mailto:eisley@sfsu.edu)>  
Date: Wed, 21 Feb 96 15:50:27 0000

The keyboard on my Sol 20 is dead. Well, a few of the vowels work, and some of the really good consonants, but more or less dead. My question is: was the keyboard on the Sol a Processor Technology design, or was it just a standard terminal keyboard? Could I replace it with another? Is it repairable? How could I determine what the problem is?

Sorry to be babbling like this to a complete stranger, but I would just love to get this friendly blue computer working again.

*That's why the Doctor is here.*

Thank god someone understands my, well, let's call it a "problem". :)

*I have a few of these myself. The keyboard is a crappy design. It uses foam pads with aluminum foil to make the "springs" that make contact. These pads turn to powder after a de-*

*cade or so. If you are at all mechanically inclined you can open it up and see. I bought some foam pads of about the right size some time ago and have thought about replacing them, but I have not done so. I think I got the pads at a hobby store or plastics supplier. I would NOT advise hand-cutting out lotsa little circles!*

Well I think I'll open up the keyboard itself and take a look. I'll let you know if I electrocute myself, and/or figure something out. Thanks!

#### Typical correspondence

To: [hjohnson@pluto.njcc.com](mailto:hjohnson@pluto.njcc.com)  
From: "Roy J. Tellason"  
<[tanstaaf@postoffice.ptd.net](mailto:tanstaaf@postoffice.ptd.net)>  
Subject: Re: S-100

One of these systems is a Cromemco System/3, which used some of the bus lines as individual select lines, rather a weird arrangement when you can deal with a whole lot more ram in the system by decoding these lines on board, but hey, I don't know what they were thinking when they designed the board... <g>

*Well, 64K \* 8 was a fair amount of memory at one time...*

Yeah. They used eight lines to select one of eight possible 64k boards, which I guess is all they thought that people would ever really need...

I remember at around the time I got that system Cromemco was pretty much into making only 68000-based systems to be used in industrial control and similar applications. Do you know anything about what ever happened to them? One of these days I'd like to begin building a chronology of some of these companies...

As of the early 1990's they were still around. Do me a favor, and I'll put your response in the next TCJ. Check out Cromemco for me under their new name:

Dynatech Computer Systems  
280 Bernardo Ave  
PO Box 7400  
Mountain View CA 94039-7400  
415-964-7400

The other box is my Imsai, which doesn't have the original boards in it. I got two rather nifty Teletek manuals with the system, one of which describes a rather nifty cpu board that's pretty complete unto itself, but it looks like I have the other one... Not sure which ram board I have in that system, and I don't think I have docs in it.

*Tell me what board and manual you have: maybe I have the others!*

I don't know what the ram board is that's in it, and I can't get into it at this point in time. The machine is sitting at the back end of a table with about a foot of space in front of it, and the terminal on top of it. (BTW, that terminal is an ADDS Viewpoint — do you have anything on that? I'd like to get WS looking right!) The two manuals I have are for a Teletek "Systemaster" (there are some spec sheets in there for their other products) and the FDC-I, which I believe is the board that's in it at the moment. Plus some sort of a 64k ram board but I can't remember any specifics on that one offhand. The one I don't have appears to need other boards for i/o but has its own ram on it, so there's the tradeoff...

I don't have much in the way of original docs for the Imsai setup, and a bunch of the front panel doesn't do anything any more since the board that ran that was apparently removed at some point in time. I recall a couple of ribbon cables with IC-type plugs on the end of them, and would like to hook these up to something so I can use those switches later on. The lights work, though... <g>

*The ribbon cable connects the front panel to the data lines of the processor. It's necessary for any front panel switch activity.*

Oh, on the subject of S100 stuff, I have a Vector motherboard that I got somewhere that would make a dandy setup for prototyping stuff. It has room for something like 6-8 slots. Problem is, I started with a blank board. This is really pretty nifty, as it has active termination on it. What I'd need to get that going is a few more parts (not a

problem) and si 00 connectors (problem). Do you have, or know of a source for those connectors?

They are available from JDR Micro-devices, sales phone# 1-800-538-5000 *100 pin S-100 edge connector, .125 centers between pins.*

Solder tab version: 100P-ST, \$4.95  
Wire Wrap version: 100P-WW, \$5.95

From: "Ken Montgomery"  
<[KENM@compctr.ccs.csus.edu](mailto:KENM@compctr.ccs.csus.edu)>  
Date: Mon, 22 Jan 1996 15:50:32  
PST  
Subject: Re: Exity Sorcerer's etc..

*As I write articles on the S-100 for The Computer Journal, I'd appreciate a bit more info on the Sorcerer for publication in my column. I've seen a few of these in my time, but I don't have one. I'd be interested in a manual set, if that is a reasonable thing to put together, and some kind of bootable disk (or tape) if I have to offer one to somebody in the future. Your recent post in comp.os.cpm was pretty good: if you would care to expand it a bit I'd be glad to publish it!*

I have 7 of them. There were several flavors of the Sorcerer. These included at least 3 revisions of the board, plus a 'Spellbinder' version and others. Yes, they used hollowed out 8-track carts for their ROM boards!

My 'archive' of Sorcerer stuff is VERY buried at this time, but 1 of my current projects is to pull out each and every one of the systems in my collection and photograph them. I'm working on building a virtual museum which I'll put up on the WWW. With the amount of information I have and the quantity of systems, it should be quite an overwhelming site! At this stage, I'm working on a general description/history of each of the types of systems (a paragraph size amount) and a description/history of that specific system(s), like who I got it from if I didn't buy it new, and what it was used for. I haven't seen anything on the net yet that has more than a half dozen systems listed, and I have over 40 unique types. I expect to put it up after I've got somewhere around a third of it done.

I'm an old SMUG member so Bill Kibler can tell you all about me. He knows I've been planning this for some time now. I'll keep you posted on my progress.

>From hjohnson Tue Jan 23 14:13:55 1996  
To: "N. White" <[normill@maple.net](mailto:normill@maple.net)>  
Subject: Repair of CP/M System 8' Drive and/or Floppy Controller Card  
Date: Tue, 23 Jan 1996 13:31:33 -0500

On Mon, 22 Jan 1996 01:16:43,  
"N. White" <[normill@maple.net](mailto:normill@maple.net)>  
wrote:

I am trying to resuscitate a S-100 bus, CP/M system, which ceased functioning suddenly about eight years ago. Running monitor diagnostics shows the CPU card and 64K RAM card to be functioning perfectly. The problem seems to lie with either the 8 inch drive, or the floppy controller card. Diagnostics on the latter show that I can move the head around o.k., but can not READ or WRITE to the disk. I have tried replacing all the TTL chips on the controller card, replacing the ribbon cable, and even swapping in an equally dubious spare 8 in. drive, but nothing works. All three cards were made by a company called 'SDK', based in Dallas, Texas. Any ideas?

SDK sounds kinda familiar. Do you have names for these boards? Docs?

IF you have an oscilloscope, try looking at the disk drive READ signal. You should have no signal until the head is loaded (touching) onto the diskette AND there is enough pressure between the head, diskette, and the head or pad on the other side. THEN, you'll see a stream of highs and lows. Even a logic probe will show the difference. Borrow one of these if necessary.

Replacing the floppy controller chip seems like the next course of action. Some older controllers used logic and even analog chips for disk reading: replacing these without retuning the circuits may cause loss of data.

*I have 8-inch drives which I can verify before shipment. Cost: around \$25 plus*

*shipping, depending on size (full heights are cheaper) or single or double sided (SS are cheaper). What drives do you have?*

To: [sporkster@cris.com](mailto:sporkster@cris.com) (Sporkster)  
From: [hjohnson@pluto.njcc.com](mailto:hjohnson@pluto.njcc.com)  
(Herbert R Johnson)  
Subject: Re: What do you do with it??  
Date: Sat, 27 Jan 1996 19:28:43 -0500

In article , you wrote:

>In article <x>, egriebel@ptdl2  
says...

\*>

\*>I love playing around with old systems and getting them working,

\*>but I never know what to do with them once I get them working

\*>(as if I had any time, anyway :-)

>

\*>I'm curious—what do you all do with your old systems?

>

\*>Use It as a door stop, paper weight, target practice, see what 600 volts will

\*>do to a motherboard, ash tray, anchor,

\*>

Some people consider small systems a challenge, or use them as part of development for various hardware (read non-PC) applications, or just as a reminder of previous work. And some people respect such folks: and *some don't.*

To: David Saad  
<[dsaad@mtest.teradyne.com](mailto:dsaad@mtest.teradyne.com)>  
Date: Thu, 01 Feb 1996 12:46:47 -0500

I got your name from an article in the the news group comp.os.cpm. I have a Northstar Horizon 64k with two single sided 160k hard sector floppies. I came across a compupro 8", 5 1/4" floppy controller but have no software to go with it. The controller rev is 17 IF, and I have the manual.

*Is this a Disk I or a Disk IA or a Disk IB?*

I have made the modifications specified in the manual for use with a 5 1/4" drive, and written some routines in turbo pascal to format the disk, but cannot get the format to complete suc-

cessfully.. Do you have any experience with this hardware combination? Or better yet do you know where I could find the Compupro software that came with the board?

I have CP/M 80 and CP/M 8/16 and CP/M 86 from Compupro for this controller. Cost for CP/M 80 is \$30 plus shipping, which includes a CP/M 80 serialized diskette (i.e. license). The disk is on 8-inch media. I don't have a 5.25 inch boot disk, check the manual (and I'll review the disk) to see how you might support 5.25 inch.

My impression is that you want to use this controller for the Northstar. In that case you have to rewrite any software from the Compupro diskette. If so, you may only want sources on diskette. I can put them on a MS-DOS disk that you could serially transfer to the Northstar via a PC compatible. That would cost \$25 plus \$5 shipping. 3.5 inch 1.44 Meg would be the format, but I could do others.

I have 8-inch floppy drives for various prices around \$25, depending on size (half or full height) or heads (single or double). Also cases and power supplies, etc. for similar prices. Shipping extra.

*I also have some SD Systems floppy disk controllers with some software intended for use in a foreign system. The software includes format and some BIOS samples, but the project is incomplete. I'd sell you a \*new\* card plus the software as it is for \$25 plus shipping. The card supports 5.25 AND 8-inch at the same time. What would you like?*

>From [JRBRADY@delphi.com](mailto:JRBRADY@delphi.com)  
Mon Jan 15 21:36:54 1996

I wanted to touch base with you regarding purchasing some S-100 equipment. Here's what I have so far:

2 - Northstar Horizons with SSDD 5-1/4" hard-sectored floppies  
(the ones I brought back to life)  
along with extra N\* Z-80  
CPU cards, memory boards, and disk controllers  
1 - PSS RAM 65 board (no documentation)

2 - PSS RAM 16 boards " "  
2 - SCP 16K Plus boards " "  
1 - SCP 16K Std. board " "  
1 - Morrow Disk Jockey 2D/B board,  
no docs, one bad regulator!

OK, these are reasonably nice systems, notwithstanding hard sectoring...  
I have docs and disks for some versions of the DJ 2D. Regulators are cheap,  
*I hope you did not fry the card otherwise!*

In addition to plain-vanilla N\* DOS, various versions of CP/M 2.2 and probably 100+ disks came with these systems (however, most of the application software is for the N\* Advantage machine which uses the DSDD "quad" hard-sectored floppies).

What I'd like to do is build a more flexible system that will support soft-sector 5-1/4" and/or 8" disks, a hard disk, additional I/O ports, and multiple 64K banks. What do you recommend? Do you feel that the N\* backplane will suffice for this project? Can you use any of the boards listed above?

I don't need any of the above, other than a mild interest in a Northstar system again. I can sell you a reasonably flexible softsectored controller from SD systems with a generic BIOS. Or/and docs for your Morrow DJ2D-B, but that's only 8-inch. The SD Versafloppy II with a preliminary 5-inch BIOS and docs is \$30 plus shipping. It is I/O mapped, unlike the memory mapped N\* stuff. I'd be kinda interested in the Morrow card, maybe you could photocopy the board and send a picture so I can figure out which version you have.

Your hard sectored disks have some incremental value: they are hard to come by these days.

On Mon, 12 Feb 1996  
<[JRBRADY@delphi.com](mailto:JRBRADY@delphi.com)> wrote:

\*>Hi Herbert,  
\*>  
\*>Just wanted to drop a note and inquire if you received the letter with the \*>lousy' photocopy of a Morrow' controller board. Any comments?

Yes, sorry for the delay - snow, new job, illness.

I have a number of these cards and find them very convenient, so I'd be interested in one. I recall it was not working, at least due to a bad regulator.

I have some new SD Systems card that are good for both 8-inch and 5-inch. I have their BIOS source, which requires an SD CPU card; and some BIOS work done by Raymond Gandia to support a 3.5 inch drive, also in source form. I can send you a card, docs, and this code. Normally this would be \$30 plus shipping; how about a \$10 + shipping credit for the DJ card, so your cost is \$20? The only issues about the SD card is 1) you need to mount an inverter on the card to change its phase 1 clock input to phase 2; and 2) it has no ROM sockets, so your BIOS or boot code must be elsewhere.

*I'd reimburse your \$20 IF you came up with a good 5.25 inch BIOS system for the card and FORMA T, and gave me the sources. The good news is that the SD card is I/O mapped, so you don't have to worry about memory conflicts. The DJ card is MEMORY mapped up at the top of memory where the Northstar I/O is!!!*

**S-10 0/1 €€€69 6**

IMS&I Altair  
Compupro Morrow  
Cromemco  
and more!

**Cards\* Docs • Systems**  
**Dr. S-100**

**Herb Johnson,**  
59 Main Blvd.  
Ciuing, NJ 08618  
(609) 771-1503

[hjohnson@pluto.njcc.com](mailto:hjohnson@pluto.njcc.com)

# Small System Support Regular Feature

By Ronald W. Anderson

68xx/68xxx support

C & Assembly

## Storage Classes And Scope of Variables

So far we haven't discussed the scope of variables in C. Here is some real code to look at:

```
/* scope of variables */
#include <stdio.h>

int x,y,z; // these are GLOBAL variables

void main()
{
    int a,b,c; // these are local to main and
              // hidden from other functions
    ....
}

void do_something()
(
    int p,q,r; // these are local to this function.
              // They don't even exist when this
              // function is not running
    .....
)

void do_something_elsei)
(
    int x; // this function now can not access the
          // global variable x. If x is used in an
          // expression it will use the local
          // variable
    .....
)

void count_events()
(
    static int count=0;

    count++;
)
```

That is enough to talk about for a while. Variables declared outside of any function including main() are global variables. They may be used by any function in the program, with limitations described a few paragraphs down.

Variables declared inside a function including main() may be used only by that function. A variable declared inside a function, that has the same name as a global variable, blocks access to that global variable within the function.

All of the variables defined in the above examples are called "automatic" variables. They come into existence when the program block in which they are declared is running. That

is, the variables p, q, and r in do\_something() are allocated space when do\_something is called. No assumptions can be made about the contents of p, q, or r. They may be the same as they were left on the last call, but if do\_something was arrived at by a different path, they may be allocated space in a different place in memory and will contain no meaningful values.

The function count() has had its variable declaration modified by the addition of the keyword "static". Static means that the variable will be allocated a permanent location in memory. A static variable is initialized only on the first call to the function, and it remains valid the next time the function is called. Count() can therefore keep track of a count of something. It is legal to use the modifier "auto" in front of variable declarations, but it is the default and leaving it out saves a lot of typing.

Static variables are used for another purpose. A C program may consist of multiple modules or files. When a global variable is declared as static it is not accessible by another program module. When a module needs to access a variable in another module (file) it declares that variable as "extern" (for external). Again it is too bad the authors of C couldn't have used a different word (local or private, for example) rather than giving the word static two different meanings depending on the context or location where they are used.

```
//program .....
static int x;    H this one is not accessible by
                H another module
int y;          H this one is accessible by another
                H module
extern int z;    U this one is in another module (or
                n there will be an error when the
                U compiler tries to find it.
```

We will talk about multiple module programs in another session.

## Files

C has provision for handling files for read and write. There are functions to provide this access:

```
FILE* fopen(char* filename, char* mode);
fclose(FILE*);
```

```
char getc(FILE*);
putc(char,FILE*);
```

Most of the C documentation is done as these are shown here. That is, the types of the return value and of the parameters are shown without any variable names associated. This information is available in the HELP file of Turbo C and it is generally how any description of the standard library functions is written in textbooks on the same subject. C has a predeclared (in a header file) data type called a file pointer. You first define one or more of these and then use them as follows:

```
FILE *infile, *outfile;

main()
{
    int ch;

    infile = fopen("data.dat","r");
    outfile = fopen("new.dat","w");
    while((ch = getc(infile)) != EOF) {
        putc(ch,outfile);
    }
    fclose(infile);
    fclose(outfile);
}
```

The function fopen() returns the file pointer type that needs to be assigned to the variable infile and outfile. If things go well the value returned is a pointer to an area of memory (defined as a structure in C) where the file is handled. If things do not go well fopen() returns a value of zero or NULL. You can use this fact to trap errors for the user and tell him what he did wrong or what didn't happen according to plan.

There are other modes than read and write. A file that exists can be opened for "append" or "update" and it can be opened in "binary mode". A text file that is going to be read into a buffer ought to be opened in just plain read mode ("r"). If it is to be copied to another file as in the above example it ought to be opened in binary mode as in "rb" and "wb". The difference is small, dealing only with how C treats the end of line character(s). Dos uses a CR and an LF at the end of each text line. C converts this to however it represents \n (generally just an LF) when it reads a file in non-binary mode. It converts the \n back to CR and LF when it writes a file in non-binary mode. In binary mode it doesn't change the value of any byte of the file, just what we want when we copy a program from one file to another.

The filenames in fopen can just as well be a character array, since they are defined as char\*:

```
char filename[];

infile = fopen(filename,"r");
```

### Command Line Arguments

C has a nice feature. It is a built-in way to handle command line arguments. Below is a program listing that uses this feature. To use it we define some parameters for main():

```
main(int argc, char* argv[])
{
    int ch;

    infile = fopen(argv[1], "rb");
    outfile = fopen(argv[2], "wb");

    while ((ch = getc(infile) != EOF) {
        putc(ch, outfile);
    }
    fclose(infile);
    fclose(outfile);
}
```

Now you have all the pieces of a genuine copy program. The command line is:

```
ccopy data.dat new.dat
```

Assuming "ccopy" is the name of our program, and we want to copy an existing file "data.dat" to a non-existing one "new.dat". Now let's look at 'argc' and 'argv'. 'argc' is just the count of arguments on the command line (items separated by spaces) In this case there are three including the name of the program. I.e. "ccopy" is the first, "data.dat" the second, and "new.dat" the third.

'argv' is declared as an array of pointers to character, or if you like an array of character arrays. 'argv[0]' points to "ccopy". 'argv[1]' points to "data.dat" and 'argv[2]' points to "new.dat". We didn't use argc in our program but we could test for user errors by expanding our program as follows:

```
// a program to copy a file to another
// syntax: ccopy infilename outfilename

#include <stdio.h>

void main(int argc, char **argv)
{
    FILE *infile, *outfile;
    int ch;

    if(argc != 3)
    {
        puts("ccopy needs input/output filenames");
        exit(1);
    }

    infile = fopen(argv[1], "rb");
    if(infile == NULL)
    {
        puts("can't open input file");
        exit(1);
    }

    outfile = fopen(argv[2], "wb");
    if(outfile == NULL)
    {
        puts("can't open output file");
        exit(1);
    }

    ch = getc(infile);
    while(!feof(infile))
    {
        putc(ch, outfile);
        ch = getc(infile);
    }
    fclose(infile);
    fclose(outfile);
    exit(0);
}
```

This is a complete working program written in the style of Pascal or other procedural languages such as PL/9. The next listing will present the program with the C shortcuts, some of which we have mentioned above. Basically the shortcuts are done by including an assignment statement inside of a while condition. Usually doing this can eliminate having to repeat a statement such as `ch = getc(infile)`; If you compare these two programs you will see the economy of the shortcuts (and also how they make the program appear more cryptic and harder to understand).

```
// program to copy a file to another
//syntax: ccopy infilename outfilename

#include <stdio.h>

void main(int argc, char* argv[])
{
    FILE *infile, *outfile;
    int ch;

    if(argc != 3)
    {
        printf("ccopy needs input/output files!\n");
        exit(1);
    }

    if((infile = fopen(argv[1], "rb")) == NULL)
    {
        printf("can't open input file");
        exit(1);
    }

    if((outfile = fopen(argv[2], "wb")) == NULL)
    {
        printf("can't open output file");
        exit(1);
    }

    while((ch = getc(infile)) != EOF) (
        putc(ch, outfile);
    )
    fclose(infile);
    fclose(outfile);
    exit(0);
}
```

These are both complete working programs that can copy a file to another file. The args can just as well be complete directory paths. Note however that we have done nothing to implement the "wildcard" features of the DOS copy program. That can be done but the program becomes much more complex. We would have to open directory records and search names of files in the directory for valid string matches somehow handling the wildcard characters and "\*" "?".

These programs can be the basis for what we call a "filter program", one that reads information from one file and changes it slightly, writing it to an output file. All we have to do is to insert some sort of process between the read and the write. For example, we might for some reason want to convert a text to all upper case or all lower case. The while loop in the program could be changed to:

```
while ((ch = getc(infile)) != EOF)
{
    ch = toupper(ch);
    putc(ch, outfile);
}
```

`toupper()` is a standard library file that returns the upper case version of a lower case character.

## Assembler

Well, so much for scope of variables and working with files. Let's get on to Assembler Programming. This time I found a program I wrote some time ago as a utility for FLEX. It allows you to examine the data on a disk by sector number. If you are going to write utility programs this is a nice tool to see exactly what was written to the disk when you wrote a file. It also allows you to look at the structure of a FLEX disk. For example the first two sectors of track 0 (0000 and 0001) contain the boot information (if the disk is a bootable one). Sector 0003 contains the name and date of the disk. Sector 0004 is blank and the directory starts at sector 0005. The remainder of track 0 is reserved for directory entries. User files start on track 1 sector 1. In the notation I am using here, the first two digits are the track and the second two the sector. Numbers are hexadecimal.

In FLEX, track 0 has sector numbers starting at 0. All other tracks start at sector 01. Seems strange, but it has to do with the way disk controllers work and being compatible with IBM format standards. The number of sectors per track depend on the disk format (and in some cases on the version of FLEX). When you dump a sector, the first two bytes that are displayed are the link to the next sector in a chain. If you are in the middle of a disk file, the link points to the next sector in the file. If you are at the end of the file the sector link is 00 00. The next two bytes contain the sector count within the file. The remaining 252 bytes of a sector are data. The program dumps a sector in both hexadecimal and ASCII representation. At the left you will see the hexadecimal such as 41 42 43 ... and at the right, the ASCII representation of the same codes, in this case ABC.... Some codes don't represent printable characters, i.e. the first 32 codes, which are control codes. SDUMP represents these as a period. Codes larger than \$7F have the high order bit removed in the ASCII representation. Therefore \$41 and SCI are both shown as ASCII A.

We need to talk a little more about the File Control Block in FLEX. If you will refer to your programmer's guide (assuming you have one), you will see that the first 64 bytes of the FCB are used for housekeeping and the last 256 hold the image of the currently in use disk sector. Bytes 30 and 31 of the FCB contain the number of the current track and sector respectively. The numbers are in binary form of course so we will treat them as hexadecimal values for purposes of specifying them. Also remember that the first byte of the FCB is byte 0, the 64th byte therefore being 63. The sector image starts at byte 64.

Now let's look at the program, which uses just a few more FLEX routines than we have used previously. This program has been written in position independent code. The command syntax and a brief description of the utility are included as comments in the Assembler source code, a good

practice for something that you are going to use for a while or give away to someone else.

```

NAME SDUMP
TTL DISK SECTOR DUMP UTILITY
OPT PAG
PAG
*
* DISK SECTOR DUMP PROGRAM
*
* FORMAT: SDUMP N WHERE N IS THE DRIVE NUMBER
* SDUMP WILL PROMPT COMMAND:
*
*
* VALID COMMANDS:
* N TTSS NEXT TRACK (TT) AND SECTOR (SS) TO BE
* DUMPED
* F FORWARD A SECTOR VIA INCREMENT OF SECTOR NUM
* B BACK A SECTOR BY SAME MECHANISM. N COMMAND MUST
* BE USED TO CHANGE TRACKS. AN INVALID SECTOR
* NUMBER WILL RESULT IN DUMPING THE PREVIOUSLY
* DUMPED SECTOR AGAIN.
*
* FLEX EQUATES FOR THIS PROGRAM
GETCH EQU $15 GET CHARACTER
GETNAM EQU $CD2D GET FILE SPEC INTO FCB (X)
DEFEXT EQU $CD33 DEFAULT EXTENSION
FMS EQU $0406 WITH FUNCTION CODE AT O.X

* 9 = READ SECTOR
* TRACK IS 30,X SECTOR IS 31,X

HEXIN EQU $CD42      GET HEX VALUE IN X
OUT2H EQU $C03C      OUTPUT 2 HEX DIGITS BYTE POINTED
                        AT BY X

PCRLF EQU $CD24      PRINT CARRIAGE RETURN LINEFEED
PSTRNG EQU $CD1E     PRINT STRING POINTED AT BY X
PUTCH EQU $CD18      OUTPUT CHAR IN ACCA TO TERMINAL
WARMS EQU $CD03      FLEX WARMSTART
*
* DEFINITIONS FOR BYTE LOCATIONS IN THE FCB
*
FUNC EQU 0
ERRCOD EQU 1
DRIVE EQU 3
TRACK EQU 30
SECTOR EQU 31
*
ORG $C100
START BRA BEGIN
VER FCB 1 VERSION NUMBER

* PROGRAM VARIABLES
*
NUMBUF RMB 2
LINCNT RMB 1
CHRCNT RMB 1
PAGEAD RMB 1
XTEMP RMB 2
*
BEGIN JSR HEXIN      GET DRIVE NUMBER FROM COMMAND
                        LINE
                        SAVE IT
                        POINT AT FCB
                        DRIVE NUMBER
                        DRIVE NUMBER

                        STX NUMBUF,PCR
                        STARTI LEAX FCB,PCR
                        LDA NUMBUF+1.PCR
                        STA DRIVE.X
                        LEAX PROMPT.PCR
                        JSR PSTRNG      PRINT THE PROMPT
                        JSR GETCH      COMMANDS ARE A SINGLE
                                        CHARACTER
                                        FORCE IT TO UPPER CASE

                        LBSR TOUPPR
                        LEAX FCB,PCR
*
* THIS IS THE COMMAND INTERPRETER
* EACH COMMAND LETTER CAUSES A BRANCH TO THE
* APPROPRIATE ACTION
*

```

```

CMPA #1
BEQ NEWTS
CMPA #1
BEQ NEXTS
CMPA #1
BEQ LASTS
CMPA #1
BNE STARTI IF COMMAND DOESN'T MATCH, START OVER
                        AGAIN
JMP WARMS IF E WE GET TO HERE AND EXIT

NEWTS LBSR GETTS NEW TRACK AND SECTOR
BSR OPAGE      SHOW THE SECTOR
BRA STARTI     GO AROUND AGAIN

NEXTS LDD TRACK,X NEXT TRACK AND SECTOR
ADDO #1
STD TRACK,X
BSR OPAGE
BRA STARTI

LASTS LDD TRACK,X PREVIOUS TRACK AND SECTOR
SUBD #1
STD TRACK,X
BSR OPAGE
BRA STARTI
*
* OUTPUT A PAGE IN HEX AND ASCII
*
OPAGE JSR PCRLF
LEAX FCB,PCR      POINT AT FCB
LEAX TRACK,X      GET TRACK AND SECTOR ID
LBSR OUT4H        OUTPUT IT TO THE SCREEN IN HEX
LEAX HEADER,PCR   POINT AT HEADER
JSR PSTRNG        PRINT IT
JSR PCRLF
LEAX FCB.PCR
LDB #9            FUNCTION CODE FOR READ SECTOR
STB FUNC.X
JSR FMS           GET THE SECTOR DATA
JSR PCRLF
*
* CLEAR LINE AND PAGE ADDRESS COUNTS
*
CLRB LINE COUNTER
STB LINCNT,PCR
STB PAGEAD,PCR
STB PAGEAD+1.PCR
LEAX FCB.PCR
LEAX 64,X        64TH FCB LOCATION IS START OF
                        SECTOR DATA
STX XTEMP,PCR    THIS IS A WAY TO SAVE A VALUE
                        FOR LATER USE

* THIS LOOP FOR EACH LINE
LLOOP LDB #16     CHAR COUNTER THE LINE LOOP
STB CHRCNT,PCR
LEAX PAGEAD,PCR  PAGE ADDRESS
JSR OUT2H        OUTPUT TO SCREEN
LOA #$20         SPACE
JSR PUTCH
LDA #$20
JSR PUTCH
LDX XTEMP,PCR    GET THE VALUE SAVED TEN LINES OR
                        SO ABOVE

* CHARACTER OR BYTE LOOP 16 BYTES PER LINE
CLOOP JSR OUT2H  OUTPUT HEX VALUE
LEAX 1,X        INCREMENT POINTER
LDA #$20        SPACE
JSR PUTCH
LDB CHRCNT.PCR  DECREMENT CHARACTER COUNT
SUBB #1
STB CHRCNT,PCR  SAVE IT
BNE CLOOP       LOOP UNTIL CHRCNT = 0
LDA #$20        SPACE
JSR PUTCH

* NOW BACK UP AND OUTPUT THE ASCII FORM

```

```

LEAX -16,X          BACK UP 16 BYTES
LDB #16            LOAD THE COUNTER
STB CHRCNT.PCR

* ASCII LOOP
ALOOP LDA ,X+      GET A BYTE
ANDA #$7F          MASK HI ORDER BIT
CMPA #$20
BGE ALI
LDA #.             IF NOT PRINTABLE SUBSTITUTE A
                  PERIOD
ALI JSR PUTCH      PUT IT TO THE TERMINAL
LOB CHRCNT.PCR
SUBB #1            DECREMENT COUNT
STB CHRCNT.PCR
BNE ALOOP         GO AROUND UNTIL ZERO

* SAVE THE ADDRESS WITHIN THE SECTOR
STX XTEMP

* INCREMENT THE PAGE ADDRESS
LDA PAGEAD.PCR    FIRST COLUMN OF OUTPUT
ADDA #16          BUMP BY 10 HEX
STA PAGEAD.PCR
JSR PCRLF         GO TO A NEW LINE
LDB LINCNT.PCR
ADDB #1           COUNT THE LINE JUST OUTPUT
STB LINCNT.PCR
CMPB #16
BNE LOOP         END OF MAIN LOOP TO PRINT 16
                  LINES

RTS

*
* SUBROUTINE TO GET A NEW TRACK AND SECTOR
*
GETTS LDB #4
STB CHRCNT.PCR   WE'RE GOING TO READ FOUR CHARS
LEAX FCB.PCR
LEAX TRACK.X     POINT X AT TRACK.SECTOR BYTES
CLR .X
CLR 1 X
LOOP JSR GETCH
JSR TOUPPR       CONVERT CHARACTER TO UPPER CASE

* NOW CONVERT TO HEX
CMPA #0
BLT ERR
CMPA #9
BGT GETPG1
SUBA #$30        IF IN RANGE 0 TO 9 ASCII
                  SUBTRACT $30

BRA SHFT
GETPG1 CMPA #A   IF IN RANGE A - F ASCII
                  SUBTRACT $3Z

BLT ERR
CMPA #F
BGT ERR         IF NOT A VALID HEX DIGIT ERROR
SUBA #$37      CONVERTS ASCII A-F TO HEX A-F
SHFT PSHS A    THIS IS A WAY TO TRANSFER
                  CONTENTS OF A TO B PULS B

CLRA

* GET THE HEX NUMBER ASSEMBLED SO FAR AND ADD THE
* NEW NYBBLE TO IT, THEN SHIFT ALL LEFT 4 PLACES

ADDD ,X
DEC CHRCNT.PCR
BEQ DONGET      IF WE'VE INPUT FOUR CHARS WE'RE
                  DONE
ASLB           OTHERWISE SHIFT WHAT WE HAVE SO
                  FAR LEFT 4 PLACES
RO LA         AND GO GET ANOTHER HEX DIGIT
ASLB
ROLA
ASLB
ROLA
ASLB
ROLA
STD .X        SAVE THE SHIFTED VALUE BACK IN
              TTSS

```

```

BRA LOOP
DONGET STD .X
RTS

* OUTPUT 4 HEX DIGITS BY CALLING FLEX OUT2H,
* INCREMENTING THE POINTER (X) AND CALLING IT AGAIN
OUT4H JSR PCRLF
      JSR OUT2H
      LEAX 1,X
      JSR OUT2H
      LEAX -1,X
      RTS

ERR LEAX MESG.PCR
JSR PSTRNG
RTS
*
* SUBROUTINE TOUPPR
* WE DID THE INVERSE LAST TIME

TOUPPR CMPA #'a IS WITHIN a-z ?
      BMI DONUP
      CMPA #'z
      BGT DONUP          IF NOT, WE'RE DONE
      SUBA #$20          ELSE MAKE IT A-Z
      DONUP RTS

MSG FCC /INVALID NUMBER/, $04
PROMPT FCC /COMMAND: /, $04
HEADER FCC /      00 01 02 03 04 05 06 OZ 08 09 OA OB
                  OC OD OE OF, $04

FCB RMB 320
END START

```

Notice that we have put some of the variables at the beginning of the program and the constant text strings and the File Control Block at the end. It is a common practice in FLEX utilities to place a version identification number just after the initial branch to the start of the program. There is a FLEX utility called VER (or version) that will report the version number of a .CMD file. Thus VER SDUMP.CMD would report 1.

Rather than a line by line description this time, I've tried to comment the code sufficiently so you can see what is going on. If you are successful at typing in and assembling this you should see something like this:

```

0101
      00 01 02 03 04 05 06 OZ 08 09 OA OB OC OD OE OF
00 41 42 43 44 45 46 47 48 49 4A 4B 4C 4D 4E 4F 50
      ABCDEFGHIJKLMNOP
0105 ETC. Q

```

The leftmost number in each line is what was called PAGEAD in the program.

This pattern will continue for 16 lines. You read the byte address within the sector as the number at the left of the line plus the number on top. Thus the 12th byte in the 5th line would be byte address 40 at the left plus OB from above or byte 4B.

We did an upper to lower case conversion last time so the TOUPPER subroutine ought to be straightforward enough.

The hardest part of this to follow is the GETTS subroutine. GETTS gets a character from the user's keyboard. If it is in the range of ASCII 0 to 9 (\$30 to \$39) we simply subtract \$30 from it to get the hexadecimal value 00 through 09. If it is within the range of ASCII A through F we subtract \$37 to get the hexadecimal values 0A through 0F. For example, A has the ASCII code \$41 hex. If we subtract \$37 from \$41 we have a result of \$0A etc. Remember this is hexadecimal arithmetic. We are not subtracting decimal 37 from decimal 41 which of course would give us a result of 4.

If the character is outside of both ranges it is an error which we trap.

Having the first digit of our desired TTSS we add it to the contents of the Track and Sector bytes which we cleared at the start of the routine and shift it left four bits. For example, we input the character 2 and we add \$02 to the cleared value and shift it left four places. TTSS then contains \$0020. Now we input 4, add it to TTSS yielding \$0024 and shift that left to yield \$0240. Get a third character, say 1 and add it yielding \$0241, shift that left yielding \$2410, get the 4th character, say A, add it to get \$241A, see that the count is 0 and exit. We are now set up to read track \$24 (decimal 36) sector \$1A (decimal 26). Assuming these are valid track and sector numbers for the disk format, we then read that sector.

This time I haven't broken the program into little pieces for explanation, but I have commented rather liberally. The only hard part is the double loop, actually two loops inside of a larger one. The structure is something like this in pseudo code:

```

while we haven't printed 16 lines
begin
  while we haven't printed 16 hex values
  begin
    print a hex value
    count it
  end

  back up 16 bytes
  while we haven't printed 16 ASCII values
  begin
    print an ASCII value
    count it
  end
  increment line count
end

```

Note that in assembler it is better to preload a counter variable with the desired count and decrement it, testing for zero with a BNE instruction. This is much more efficient than counting up and having to do a CMP A #16 followed by a BNE instruction. That is, the BNE is an automatic compare with zero. The code is smaller and it runs faster.

Let me continue this discussion with a bit on the trade off between execution speed and code size. Suppose you want to write a subroutine to output n characters (all the same) and return. If you want to save space you might write a subroutine:

```

CHARS JSR PUTCHR
      DECB
      BNE CHARS
      RTS

```

In the program you would use CHARS:

```

LDA "*"
LDB #12
BSR CHARS

```

CHARS would output 12 "stars" and return.

If you were interested in speed and were certain you would never need more than, say, 15 characters output, you could use:

```

CHAR15 JSR PUTCHR
CHAR14 JSR PUTCHR
CHAR13 JSR PUTCHR
CHAR12 JSR PUTCHR
CHARU  JSR PUTCHR
CHAR10 JSR PUTCHR
CHAR9  JSR PUTCHR
CHAR8  JSR PUTCHR
CHAR7  JSR PUTCHR
CHAR6  JSR PUTCHR
CHAR5  JSR PUTCHR
CHAR4  JSR PUTCHR
CHAR3  JSR PUTCHR
CHAR2  JSR PUTCHR
CHAR1  JSR PUTCHR
      RTS

```

You've figured this out already, but you output ten characters by loading A with the character and doing a BSR CHAR10. You enter at whatever label and fall through the lower labels to the RTS. This comes in the "cute trick" category and there are more complex variations of it such as entering in the middle of a loop and going around to code before the entry point. Generally cute tricks are hard for someone else to understand and ought to be avoided. Some of these are holdovers from the days when every byte of memory was dear (when we had 4K to work with rather than 4 meg), or when processing was so slow that we resorted to tricks to speed up the execution.

This is a dumb example of course since you wouldn't be worried about speed of execution if you were simply outputting characters to a terminal. Another way to reduce both execution time and code is to avoid doing anything inside a loop that only needs doing once outside of it. In this example we have the loading of the character to be output. PUTCHR in FLEX requires the character to be in the A accumulator, and the routine doesn't change the contents of A, so we need only load it once. I've also used the trick mentioned above of preloading the B accumulator with the count and decrementing it so we can test for 0 rather than comparing with a value stored elsewhere.

New Feature  
Chip and Device  
Programming

# Program This! 8051 Startup Code

By Dave Baldwin

Some of you may wonder about 'Startup Code'? Well, you do have to start somewhere. Actually, every system requires 'startup' or 'boot' code to set up the initial operating conditions. And, it turns out that some microcontrollers require a certain startup sequence. This article and the program that goes with it is a result of the problems I had the first time I had to use the 8031, the rom-less version of the 8051.

## The Problem

I put the prototype board together and burned a simple test program I got from the Phillips BBS into an eprom. I chose the program because it was supposed to exercise the serial and timer interrupts and I was planning on using both in my design. I plugged the chips in and turned on the power expecting to see the serial port spit out the test messages. Nothing happened. I checked the board, found some errors, fixed some errors, and tried again. Still nothing. I dug out an 8031 board I had that was known to work, plugged the eprom and the 8031 into it and tried again. Nothing again.

I was using the CMOS Intel 80C31BH in the design. I found an NMOS 8031 and put that in there and it appeared to mostly work. I tried the rest of the (brand new) CMOS samples I had and they didn't. Since I had designed the board for the CMOS version, this seemed really odd. A friend gave me a monitor program that didn't use interrupts and I tried that. It worked on all the versions of the 8031 that I had, both NMOS and CMOS. That means my problem was in the interrupt code AND that there was something different between the NMOS and CMOS versions.

```

; DIBs 80x31/51 skeleton for interrupt driven serial comm programs
; for the MetaLink assembler. Works on 8032 and should work on most
; other variations.
; By Dave Baldwin, May 1996
;
; Program does not expect or use external ram.
; The 80x31/51 begins execution at 0000h but has to jump immediately
; since location 03h is the beginning of the interrupt vectors
;
$MOD51 ;8051 definition table for MetaLink assembler
; EQUATES
; timer 0 count 50 mS (0b400h is 46080 = 11.0592MHz / 20Hz)
; since timers are up-counters, subtract: 10000h-0b400h = 5c00h
; normally 50 mS, 20 mS for test
TIMOLO EQU 0
TIMOHI EQU 0B8H ; 20mS
; TH0 values for different counts
TIM005 EQU OEEH ;for 5mS
TIM010 EQU ODCH ;for 10mS
TIM016 EQU 0C4H ;for 16.67mS
TIM020 EQU OB8H ;for 20mS
TIM025 EQU OA6H ;for 25mS
TIM030 EQU 094H ;for 30mS
TIM050 EQU 05CH ;for 50mS
;
; R6 loop count for timer 0 int routine
TOCNT EQU 16
; Timer 1 baud rates for 11.0592 MHz xtal, SMOD = 0
BAUD96 EQU OFDH; 9600
BAUD48 EQU OFAH; 4800
BAUD24 EQU OF4H; 2400
BAUD12 EQU 0E8H; 1200
;
TXFLAG EQU 7FH ; bit addressable location, not part of PSW
TX_BUF EQU 40H ; locations 40h - 4Fh are the transmit fifo
; TX_HED and TX_TAL are the head and tail
TX_HED EQU 12H
TX_TAL EQU 13H
TX_CNT EQU 14H
;
RCVBUF EQU 50H ; locations 50h - 5Fh are the recv fifo
; RCVHED and RCVTAL are the head and tail
RCVHED EQU 15H
RCVTAL EQU 16H
RCVCNT EQU 17H
;
MSGCNT EQU 18H ;counter for main loop message test
; =====
; Beginning of rom, INTERRUPT VECTORS, 3 bytes each.
ORG 0
BEGIN:
LUMP START ;jump to start of program
; External Interrupt IEO (from /INT0 pin) (org 3)
RETI ;put jump to your own routine here
;
ORG 000BH ; vector for timer0/TFO overflow
LJMP TO_ISR ; go to interrupt service routine
;
ORG 0013H ; vector for IE1 (from /INT1 pin)
RETI ;put jump to your own routine here
;
ORG 001BH ; vector for timer1/TF1 overflow
RETI ; used as baud rate generator here
;
ORG 0023H ; vector for serial interrupts
LJMP SERIAL ; go to handler
; This is the earliest place to put an ID string in the rom.
DB 'DIBs8051',0

```

I put my interrupt test program and the 80C31. back in the board and reached for the scope and started poking around. At the serial port transmit output were some odd pulses, nothing that looked like standard serial output. Other pins seemed to be alright. I got out all my 8051 books, I mean all of them. They were stacked on the desk, the workbench, and the chairs. I went back and forth between the books and the program for several hours. I decided that the order of the instructions looked a little odd, so I started reorganizing the code to make sure the all the required registers were setup in what looked like the correct order. I also called the Intel help line to ask them. The person who answered tried to be helpful, but couldn't tell me what might be wrong.

Finally, after several tries and cross checking the books and some sample code, the board finally came alive and started sending out the test messages. And the second board worked also. Apparently, the CMOS version (80C31BH) was much pickier about the initialization order. I tried an 80C32 and it worked fine also. I've now used this program on five different 8051/31 boards and it works on all of them.

I have since found out that there several microcontrollers that are picky about the startup sequence. I've been told that the 68HC11 has some things that have to be done in the first 64 clock cycles after power-on or a reset and I hope someone will provide an article on that later this year. We might have some articles on appropriate start-up code for systems and applications also.

### The Code

The startup program is written for the ML-ASM51. assembler from Meta-Link which I use for my 8031 work. It is a macro assembler though I haven't used that part of it and it uses standard Intel syntax. It includes definition files for many 8051 variations. Meta-Link has made this available for free on the Phillips/Signetics BBS for a number of years and gave me permission to post it on the TCJ/DIBs BBS and the TCJ Web page so that TCJ readers could get it also.

```

;-----
; Start of program code
;-----
        ORG    40H ; start program at location 40 hex.
START:
; The first code we do is to initialize the CPU state.
INIT: CLR EA      ; clear the master interrupt enable
      MOV SP,#60H ; move the stack to free space
; SFR initializations
      CLR TRO ; CLEAR the run bit for timer 0
      CLR TR1  ; timer 1 must be disabled to put the serial
              ; port in interrupt mode
; setup timers and TimerO constants
      MOV TMOD,#21H ; mode 1 for timer 0, and 2 for timer 1
      MOV TLO,#TIMOLO ; set reload counts for timer 0
      MOV THO,#TIMOHI ;
; set up some things for timer 0 interrupt
      MOV R6,#TOCNT ; R6 is decremented once for each TO interrupt,
; setup serial stuff
      CLR TXFLAG ; clr txflag, no transmission in progress yet
      MOV TH1,#BAUD96 ; auto-reload value for 9600 baud
      MOV TL1,#BAUD96 ; ASSUMES 11.0592 MHz crystal
      MOV SCON,#50H ; set up serial control, normal uart 8-bit
              ; sets REN, clears TI/RI
; Clear the head and tail pointers for the transmit and recv fifos
      CLR A      ; zero the Accumulator
      MOV TX HED,A ; head, tail and count for Tx fifo
      MOV TX TAL,A
      MOV TX CNT,A
      MOV RCVHED,A ; head, tail and count for recv fifo
      MOV RCVTAL,A
      MOV RCVCNT,A
; now that setup is done, start the timers
      SETB TRO   ; set the run bit for timer 0
      SETB TR1  ; set the run bit for timer 1
; Enable interrupts in this order, master enable last
      SETB ES   ; enable serial interrupts
      SETB ETO  ; enable the interrupt for timer 0
      SETB EA   ; set the master interrupt enable bit
; set message index for main loop and first char for to loop
      MOV R7,#0 ; set index
      MOV R5,#41H ; char 'A'
      MOV MSGCNT,#1H ; set counter to skip message first time
; Send signon message
      MOV DPTR,#DIBMSG ; get ptr for dibmsg
      LCALL AZMSG ; ASCIIZ message routine
      SJMP MAIN ; initialization done, jump to main loop
*****
; The main loop code is responsible for watching serial inputs (and
; for echoing serial outputs). It also checks a counter and sends a
; message each time it reaches 0.
;-----
MAIN:
; check for serial input first
MLUP: LCALL   RECV      ; Check for received character
      JZ MLUP02 ; skip if there was no character,
      LCALL   SEND     ; echo it if there was
; Check counter to see if it's time to send the periodic message
MLUP02: MOV   A,MSGCNT ; get count
        JNZ  MLUP    ; loop if not zero
        LCALL SNDMSG ; call message routine
        SJMP MLUP   ;
; end of main loop
*****
; Message routine - finds current message to send
; and updates index (R7), char register (R5), and counter (MSGCNT).
SNDMSG:
SNDMS1: CJNE R7,#1,SNDMS2 ;
        MOV DPTR,#MSG1 ;get ptr for msg1
        SJMP SNDMS9 ;
SNDMS2: CJNE R7,#2,SNDMS3 ;
        MOV DPTR,#MSG2 ;get ptr for msg2
        SJMP SNDMS9 ;
SNDMS3: CJNE R7,#3,SNDMS4 ;
        MOV DPTR,#MSG3 ;get ptr for msg3
        SJMP SNDMS9 ;
SNDMS4: CJNE R7,#4,SNDMS5 ;
        MOV DPTR,#MSG4 ;get ptr for msg4
        SJMP SNDMS9 ;
SNDMS5: CJNE R7,#5,SNDMS6 ;
        MOV DPTR,#MSG5 ;get ptr for msg5
        SJMP SNDMS9 ;
SNDMS6: CJNE R7,#6,SNDMS7 ;
        MOV DPTR,#MSG6 ;get ptr for msg6
        SJMP SNDMS9 ;
SNDMS7: CJNE R7,#7,SNDMS8 ;

```

```

MOV DPTR,#MSG7 ;get ptr for msg7
SJMP SNDMS9 ;
SNDMS8: MOV R7,#0 ;clear msg index counter
MOV R5,#21H ;reset tO loop char
MOV DPTR,#XMSG ;get ptr for xmsg (msgO)
SNDMS9: LCALL AZMSG ;
MOV MSGCNT,#1FH ;reset counter to prevent bogus messages
INC R7 ;inc msg index
RET
;*****
; Function to send a char through the fifo (char in B register).
; Fifo functions write to tail, read from head, holds only 16 bytes.
; Sets the ACC to Offh if the send was Ok and clears it otherwise.
SEND: CLR EA ; disable interrupts
PUSH PSW ; save old register bank
SETB RSO ; get to register bank 1
CLR RS1 ;
MOV A,TX CNT ; get count
JNZ QUE END ; add to fifo if bytes are already in the fifo
JB TXFLAG,QUE_SND ; also put in fifo if a transmit is in
; progress
MOV SBUF,B ; send char immediately
SETB TXFLAG ; set user flag to show transmit in progress
MOV A,#0FFH ; set success
SJMP SNDEXIT
; Put byte in queue
QUE_SND: SUBB A,#10H ; max count
JZ SNDEXIT ; if zero, fifo is full
; Otherwise add the char to the fifo
MOV A,#TX BUF ; get base address of tx fifo
ADD A,TX_TAL ; add offset to tail
MOV RO,A ; get result in a register for indirect address
MOV @RO,B ; put byte in fifo
; now adjust ptr and count in memory
INC TX_TAL;
ANL TX_TAL,#0FH;
INC TX CNT
MOV A,#OFFH ;set success
SNDEXIT: POP PSW
SETB EA ; re-enable interrupts
RET
; Function to check for recvd char's If a char is ready, the ACC bit
; will be set to Offh and the character will be in the B register
; Otherwise, the ACC is cleared and the B register is undefined
RECV: CLR EA ; disable interrupts
PUSH PSW ; save old register bank
MOV A,RCVCNT ; get count
JZ RECV_END ; if 0, no char available
SETB RSO ; get to register bank 1
CLR RS1 ;
GET_IT: MOV A,#RCVBUF ; get addr of recv buffer
ADD A,RCVHED ; add head ptr
MOV RO,A ; register for indirect address
MOV B,@RO ; fetch the char
; adjust ptr and count in memory
INC RCVHED
ANL RCVHED,#OFH
DEC RCVCNT
MOV A,#0FFH ; set success flag
RECV_END: POP PSW
SETB EA ; re-enable interrupts
RET
;*****
; define a handler for the serial interrupt
SERIAL: CLR EA ; disable interrupts
PUSH ACC ; save the Accumulator, B register, and flags
PUSH PSW ; we do a bank switch to bank 1
SETB RSO ; select register bank 1
CLR RS1 ;
JNB RI,TX_OP ; ; jump if the Rx bit was not set
; Otherwise, drop into recv code
CLR RI ; clear the receive interrupt bit
MOV A,RCVCNT ; get recv count
CJNE A,#10H,RCV_STO ; if not max, then store char
SJMP NO_ROOM ; else the fifo was full, so discard this char
RCV_STO: MOV A,#RCVBUF ; store this char
MOV A,#RCVBUF ; get the base of the recv fifo
ADD A,RCVTAL ; add the offset to the tail
MOV RO,A ; get the result into a register
MOV PRO,SBUF ; move the char into the fifo
; adjust mem ptr and count
INC RCVTAL ;

```

As usual, the first part of the file is a bunch of equates for useful constants like the serial port baud rates and different timer constants. The executable code starts with the reset and interrupt vectors. In the 8051 family, all of the interrupt vectors are 'hardwired' specific ROM locations starting with the RESET vector at 0.

Next comes the Initialization routines which are the ones that turned out to be critical. Although the interrupts are disabled at power-up and reset, the first thing I do is clear them anyway. That way, I'm sure they're off and I can also call the routines later in the program if I want. Next I move the stack up to an unused memory area. The 8051/31 requires the stack to be in internal memory which is only 128 bytes. The 8052/32 expands that to 256 bytes.

Now I make sure the timers are Off and load the time constants for them and initialize memory locations used by the routines. Timer 1 is used for a periodic interrupt and Timer 0 is the baud rate generator. SCON sets up the serial port and following that is the setup for the receive and transmit fifos.

I have everything setup now and I can start turning things on. First I enable the timers so they will start running. Next I enable the interrupts leaving the master enable until last. The last thing before the Main program is to send the sign-on message.

The program that follows just exercises the timers and serial port. The Main loop checks for a serial input and echoes it if it's there and then checks the MSGCNT flag to see if the timer 0 interrupt has decremented it to 0. If it has, the SNDMSG routine is called to send one of 8 different messages.

The rest of the file contains the message handling routines, the serial and timer interrupt service routines, and the serial fifo handling routine. And that's all there is to it.

This program (DIBS8051.ASM) and the ML-ASM51 cross-assembler are available on the TCJ Web pages and the TCJ/DIBs BBS. The BBS also has a lot of other 8051 related files.

```

        ANL RCVTAL,#OFH ;
        INC RCVCNT ;
NO ROOM:                ; Fall through to check TI
; Transmit portion of interrupt
TX_OP:                  ; operations done when tx is set
        JNB TI,SER_RET ; break out of this
        CLR TI          ;clear transmit interrupt for next int
        MOV A,TX CNT ; get Tx count
        JNZ CH_SND     ;send next char
        CLR TXFLAG ;no byte available, clear tx-in-use flag
        SJMP SER_RET ; then return
CH_SND:
        MOV A,#TX BUF ; get the base of the Tx buffer
        ADD A,TX_HED ; add the offset to the head
        MOV RO,A      ; get the addr into a register
        MOV SBUF,CRO ; send the char to the output
        SETB TXFLAG   ;set user flag for transmit in progress
;adjust mem ptr and count
        INC TX_HED    ;
        ANL TX^HED,#OFH ;
        DEC TX CNT    ;
SER_RET:
        POP PSW
        POP ACC
        SETB EA      ; re-enable interrupts
        RETI         ; return from interrupt
*****
;
; define the interrupt handler for timer 0
; provides periodic interrupts
;
to ISR: CLR EA        ; disable interrupts
        PUSH ACC     ; save the Accumulator
        PUSH PSW
        CLR RSO      ;select register set 0 where 'TOCNT' is.
        CLR RS1      ;
;reset/restart timer 0
        CLR TRO      ;clear thetorunbit
        MOV TLO,#TIMOLO ; reset the counts
        MOV THO,#TIMOHI ;
        SETB TRO ; set the run bit for timer 0 again
;dec and test message loop count
        DJNZ R6,TOEXIT
; if end of count, send char from R5
        MOV B,R5 ;put char variable from R5 into B
        LCALL SEND ;let send put it in the fifo
        MOV R6,#TOCNT ;reset tO message loop count
        INC RS      ;next char
TOEXIT:
;for azmsg test
        INC MSGCNT ; inc main loop message counter
        POP PSW
        POP ACC
        SETB EA ; re-enable interrupts
        RETI ; return from interrupt
*****
;send ASCIIZ message, enter with pointer to msg in DPTR.
;
AZMSG:
        MOV R2,#0 ;clear byte counter
AZMSG1: CLR A ;
        MOVC A,@A+DPTR ;get byte
        JZ AZMSGXT ;zero is terminator
        MOV B,A ;
        LCALL SEND ;
        INC R2 ;inc byte count
        INC DPTR ;inc byte pointer
        SJMP AZMSG1 ;
AZMSGXT:
; *** un-comment the next line to show the byte count
; for each message at P1
; MOV P1,R2 ;output count at P1
        RET
; Messages
dibmsg:
        DB ODH,OAH,'DIBs8051!',ODH,OAH,0,'????????',0
;main loop messages
XMSG: DB ODH,OAH,OAH,'MsgO -==>',0
MSG1: DB ODH,OAH,'Msg1 -==>',0
MSG2: DB ODH,OAH,'Msg2 -==>',0
MSG3: DB ODH,OAH,'MsgS -==>',0
MSG4: DB ODH,OAH,'Msg4 -==>',0
MSG5: DB ODH,OAH,'Msg5 -==>',0
MSG6: DB ODH,OAH,'MsgS -==>',0
MSG7: DB ODH,OAH,'Msg7 -==>',0
;
        END ; end of assembly

```

# DIBs

Electronic Design

Dave Baldwin

Microprocessor, Digital, and  
Analog circuit design.  
PC layout and more.

Voice (916) 722-3877  
Fax (916) 722-7480  
BBS (916) 722-5799

# The TC J Store

## Regular Items

### Back Issues..... See page 44

All Back Issues of TCJ are available.

### TCJ Reference Cards..... \$3.00 + \$1 S+H

So far all we have is the Z80 Instruction Set card from Issue #77. These are on heavier stock than the one sent with the issue.

The next two items are Group Purchase items. TCJ doesn't have the resources to stock these for you, so we have to collect a minimum number of orders before we can provide these.

### \*GIDE kits..... US\$73

Tilmann Reh's GIDE board was featured in several issues of TCJ. It is a 'Generic' IDE board for the Z80 that plugs into the Z80 socket (you plug the Z80 back into the GIDE board). This is still an experimenters kit. Sample code and docs including the articles from TCJ are provided, but you have to write your own BIOS routines. Z80 assembly language experience required. Group purchase requirement - minimum 7 orders.

### CP/M CD-ROM..... US\$25 + \$4 S+H

This is the Walnut Creek CP/M CD-ROM (normally \$39.95+S&H) with 19,000 files from Jay Sage, David McGlone, FOG (First Osborne Group), the Beehive BBS, the Enterprise BBS, [ftp.demon.uk](http://ftp.demon.uk), and the SimTel20 CP/M collection from the Internet. Since we don't have CD-ROM reader software for the GIDE (yet), this requires one of those other kinds of computers to read it and a comm program to transfer it to your CP/M system. Group purchase requirement - minimum 17 orders.

## Special Items

We currently have two each of Tilmann Reh's **CPU280** boards and the IDE boards that go with them. The CPU280 was featured as the Centerfold in Issue #77 and the IDE interface was in Issue #56. They are ECB bus plug-in cards. These are bare boards and are not for the faint of heart. They are expensive and the parts are hard to get. Some of the parts are obsolete, especially the Z280 CPU chip.

### \*CPU280 bare board.....\$150

Comes with docs and utility disk.

### \*IDE bare board..... \$ 65

Comes with docs.

### \*CPU280 & IDE together.....\$200

TCJ can accept credit card orders by phone, fax, or mail or you can place an order by sending a check to:

### The Computer Journal

PO Box 3900, Citrus Heights  
CA 95611-3900

Phone: 800-424-8825 or 916-722-4970

Fax 916-722-7480 / BBS 916-722-5799

Include your shipping address with your check, and your Internet address if you have one. For more info, contact TCJ via E-mail at [tcj@psyber.com](mailto:tcj@psyber.com)

\* In Europe and particularly Germany, contact Tilmann Reh for a current price and shipping. His email address is: "TILMANN.REH@HRZ.uni-siegen.d400.de"

His postal address is:

Tilmann Reh  
Autometer GmbH  
Kaenerbergstrasse 4  
57076 Siegen (optional "-Weidenau")  
GERMANY

---

## Regular Feature SUPPORT GROUPS FOR THE CLASSICS

### Contact Listing

---

#### TCJ STAFF CONTACTS

TCJ Editor: Dave Baldwin, (916)722-4970, FAX (916)722-7480 or TCJ BBS (916) 722-5799 (use "computer", "journal", pswd "subscriber" as log on), Internet [dibald@netcom.com](mailto:dibald@netcom.com), CompuServe 70403,2444, [tcj@psyber.com](mailto:tcj@psyber.com).

TCJ Adviser: Bill D. Kibler, PO Box 535, Lincoln, CA 95648, (916)645-1670, GEnie: B.Kibler, CompuServe: 71563,2243, E-mail: [kibler@psyber.com](mailto:kibler@psyber.com).

32Bit Support: Rick Rodman, 1150 Kettle Pond Lane, Great Falls, VA 22066-1614. Real Computing BBS or Fax: +1-703-759-1169. E-mail: [ricker@erols.com](mailto:ricker@erols.com)

Kaypro Support: Charles Stafford, 4000 Norris Ave., Sacramento, CA 95821, (916)483-0312 (eves). Also sells Kaypro upgrades. CIS 73664,2470 ([73664.2470@compuserve.com](mailto:73664.2470@compuserve.com)).

S-100 Support: Herb Johnson, 59 Main Blvd. Ewing, NJ 08618 (609)771-1503. Also sells used S-100 boards and systems. E-mail: [hjohnson@pluto.njcc.com](mailto:hjohnson@pluto.njcc.com).

6800/6809 Support: Ronald Anderson, 3540 Sturbridge Ct., Ann Arbor, MI 48105.

Z-System Support: Jay Sage, 1435 Centre St. Newton Centre, MA 02159-2469, (617)965-3552, BBS: (617)965-7046; E-mail: [Sage@ll.mit.edu](mailto:Sage@ll.mit.edu). Also sells Z-System software.

#### REGULAR CONTRIBUTORS

Brad Rodriguez, Box 77, McMaster Univ., 1280 Main St. West, Hamilton, ONT, L8S 1CO, Canada, E-mail: [bj@headwaters.com](mailto:bj@headwaters.com).

Frank Sergeant, 809 W. San Antonio St., San Marcos, TX 78666, E-mail: [pygmy@pobox.com](mailto:pygmy@pobox.com).

Tilman Reh, Germany, E-mail: [tilmann.reh@hrz.uni-siegen.d400.de](mailto:tilmann.reh@hrz.uni-siegen.d400.de). Has many programs for CP/M+ and is active with Z180/280 ECB bus/Modular/Embedded computers. Microcontrollers (8051).

Helmut Jungkunz, Munich, Germany, ZNODE #51, 8N1, 300-14.4, +49.89.961 45 75, or CompuServe 100024,1545.

#### USER GROUPS

Connecticut CP/M Users Group, contact Stephen Griswold, PO Box 74, Canton CT 06019-0074, BBS: (203)665-1100. Sponsors Z-fests.

SMUG, Sacramento Microcomputer Users Group, PO Box 161513, Sacramento, CA 95816-1513, BBS: (916)372-3646. Publishes newsletter, \$15.00 membership, meetings at SMUD 6201 S St., Sacramento CA.

CAPDUG: The Capital Area Public Domain Users Group, Newsletter \$20, Al Siegel Associates, Inc., PO Box 34667, Bethesda MD 20827. BBS (301) 292-7955.

NOVAOUG: The Northern Virginia Osborne Users Group, Newsletter \$12, Robert L. Critics, 7512 Fairwood Lane, Falls Church, VA 22046. Info (703) 534-1186, BBS use

CAPDUG's.

The Windsor Bulletin Board Users' Group: England, Contact Rodney Hannis, 34 Falmouth Road, Reading, RG2 8QR, or Mark Minting, 94 Undley Common, Lakenheath, Brandon, Suffolk, IP27 9BZ, Phone 0842-860469 (also sells NZCOM/Z3PLUS).

NATGUG, the National TRS-80 Users Group, Roger Storrs, Oakfield Lodge, Ram Hill, Coalpit Heath, Bristol, BS17 2TY, UK. Tel: +44 (0)1454 772920.

L.I.S.T.: Long Island Sinclair and Timex support group, contact Harvey Rait, 5 Peri Lane, Valley Stream, NY 11581.

ADAM-Link User's Group, Salt Lake City, Utah, BBS: (801)484-5114. Supporting Coleco ADAM machines, with Newsletter/BBS..

Adam International Media, Adam's House, Route 2, Box 2756, 1829-1 County Rd. 130, Pearland TX 77581-9503, (713)482-5040. Contact Terry R. Fowler for information.

AUGER, Emerald Coast ADAM Users Group, PO Box 4934, Fort Walton Beach FL 32549-4934, (904)244-1516. Contact Norman J. Deere, treasurer and editor for pricing and newsletter information.

MOAUG, Metro Orlando Adam Users Group, Contact James Poulin, 1146 Manatee Dr. Rockledge FL 32955, (407)631-0958.

Metro Toronto Adam Group, Box 165, 260 Adelaide St. E., Toronto, ONT M5A 1NO, Canada, (416)424-1352.

Omaha ADAM Users Club, Contact Norman R. Castro, 809 W. 33rd Ave. Bellevue NE 68005, (402)291-4405. Suppose to be oldest ADAM group.

Vancouver Island Senior ADAMphiles, AD VIS A newsletter by David Coble, 17-885 Berwick Rd. Qualicum Beach, B.C., Canada V9K 1N7, (604)752-1984. [dcoble@qb.island.net](mailto:dcoble@qb.island.net)

Northern Uliana ADAMS User's Group, 9389 Bay Colony Dr. #3E, Des Plaines IL 60016, (708)296-0675.

San Diego OS-9 Users Group, Contact Warren Hrach (619)221-8246, BBS: (619)224-4878.

The San Diego Computer Society (SDCS) is a broad spectrum organization that covers interests in diverse areas of software and hardware. It is an umbrella organization to various Special Interest Groups (SIGs). Voice information recordings are available at 619-549-3787.

The Dina-SIG part of SDCS is primarily for Z-80 based computers from Altair to Zorba. The SIG sponsored BBS - the Elephant's Graveyard (619-571-0402) - is open to all callers who are interested in Z-80 and CP/M related machines and software. Contact Don Maslin, head of the Dina-SIG and the sysop of the BBS at 619-454-7392. Email: [donm@cts.com](mailto:donm@cts.com).

ACCESS, PO Box 1354, Sacramento, CA 95812, Contact Bob Drews (916)423-1573. Meets first Thursdays at SMUD 59Th St. (ed. bldg.).

Forth Interest Group, PO Box 2154, Oakland CA 94621 510-89-FORTH. International support of the Forth language, local chapters.

The Pacific Northwest Heath Users Group, contact Jim Moore, 1554 - 16th Avenue East, Seattle, WA 98112-2807. Email: [be483@scn.org](mailto:be483@scn.org).

The SNO-KING Kaypro User Group, contact Donald Anderson, 13227 2nd Ave South, Burien, WA 98168-2637.

SeaFOG (Seattle FOG User's Group, Formerly Osborne Users Group) PO Box 12214, Seattle, WA 98102-0214.

## OTHER PUBLICATIONS

*The Z-Letter*, supporting Z-System and CP/M users. David A J. McGlone, Lambda Software Publishing, 149 West Hillard Lane, Eugene, OR 97404-3057, (541)688-3563. Bi-Monthly user oriented newsletter (20 pages+). Also sells CP/M Boot disks, software.

*The Analytical Engine*, by the Computer History Association of California, 3375 Alma, Suite 263, Palo Alto, CA 94306-3518. An ASCII text file distributed by Internet, issue #1 was July 1993. Home page: <http://www.chac.org/chac/> E-mail: [engine@chac.org](mailto:engine@chac.org)

*Z-100 LifeLine*, Steven W. Vagts, 2409 Riddick Rd. Elizabeth City, NC 27909, (919)338-8302. Publication for Z-100 (an S-100 machine).

*The Staunch 8/89'er*, Kirk L. Thompson editor, PO Box 548, West Branch IA 52358, (319)643-7136. \$15/yr(US) publication for H-8/89s.

*The SEBHC Journal*, Leonard Geisler, 895 Starwick Dr., Ann Arbor MI 48105, (313)662-0750. Magazine of the Society of Eight-Bit Heath computerists, H-8 and H-89 support.

*Sanyo PC Hackers Newsletter*, Victor R. Frank editor, 12450 Skyline Blvd. Woodside, CA 94062-4541, (415)851-7031. Support for orphaned Sanyo computers and software.

*the world of 68' micros*, by FARNA Systems, PO Box 321, Warner Robins, GA 31099-0321. E-mail: [dsrtfox@delphi.com](mailto:dsrtfox@delphi.com). New magazine for support of old CoCo's and other 68xx(x) systems.

*Amstrad PCW SIG*, newsletter by Al Warsh, 6889 Crest Avenue, Riverside, CA 92503-1162. \$9 for 6 bi-monthly newsletters on Amstrad CP/M machines.

*Historically Brewed*, A publication of the Historical Computer Society. Bimonthly at \$18 a year. HCS, 2962 Park Street #1, Jacksonville, FL 32205. Editor David Greelish. Computer History and more.

*IQLR* (International QL Report), contact Bob Dyl, 15 Kilburn Ct. Newport, RI 02840. Subscription is \$20 per year. Email: [IQLR@nccnet.com](mailto:IQLR@nccnet.com).

*QL Hacker's Journal* (QHJ), Timothy Swenson, 5615 Botkins Rd., Huber Heights, OH 45424, (513) 233-2178, sent mail & E-mail, [swensote@ss2.sews.wpaafb.af.mil](mailto:swensote@ss2.sews.wpaafb.af.mil). Free to programmers of QL's.

*Update Magazine*, PO Box 1095, Peru, IN 46970, Subs \$18 per year, supports Sinclair, Timex, and Cambridge computers. Email: [fdavis@holli.com](mailto:fdavis@holli.com).

## SUPPORT BUSINESSES

Hal Bower writes, sells, and supports B/PBios for Ampro, SB 180, and YASBEC. \$69.95. Hal Bower, 7914 Redglobe Ct., Severn MD 21144-1048, (410)551-5922.

Sydex, PO Box 5700, Eugene OR 97405, (541)683-6033. Sells several CP/M programs for use with PC Clones ('22Disk' format/copies CP/M disks using PC files system).

Elliam: Associates, PO Box 2664, Atascadero CA 93423, (805)466-8440. Sells CP/M user group disks and Amstrad PCW products. Email:??

Discus Distribution Services, Inc. sells CP/M for \$150, CBASIC \$600, Fortran-77 \$350, Pascal/MT+ \$600. 8020 San Miguel Canyon Rd., Salinas CA 93907, (408)663-6966.

Microcomputer Mail-Order Library of books, manuals, and periodicals in general and H/Zenith in particular. Borrow items for small fees. Contact Lee Hart, 4209 France Ave. North, Robbinsdale MN 55422, (612)533-3226.

Star-K Software Systems Corp. PO Box 209, Mt. Kisco, NY 10549, (914)241-0287, BBS: (914)241-3307. SK\*DOS 6809/68000 operating system and software. Some educational products, call for catalog.

Peripheral Technology, 1250 E. Piedmont Rd., Marietta, GA 30067, (404)973-2156. 6809/68000 single board system. 68K ISA bus compatible system.

Hazelwood Computers, RR#1, Box 36, Hwy 94@ Bluffton,, Rhineland, MO 65069, (314)236-4372. Some SS-50 6809 boards and new 68000 systems.

AAA Chicago Computers, Jerry Koppel, (708)681-3782. SS-50 6809 boards and systems. Very limited quantity, call for information.

MicroSolutions Computer Products, 132 W. Lincoln Hwy, DeKalb, IL 60115, (815)756-3411. Make disk copying program for CP/M systems, that runs on CP/M systems, UNIFROM Format-translation. Also PC/Z80 CompatiCard and UniDos products. Web page: <http://www.micro-solutions.com>.

GIMIX/OS-9, GMX, 3223 Arnold Lane, Northbrook, IL 60062, (800)559-0909, (708)559-0909, FAX (708)559-0942. Repair and support of new and old 6800/6809/68K/SS-50 systems.

n/SYSTEMS, Terry Hazen, 21460 Bear Creek Rd, Los Gatos CA 95030-9429, (408)354-7188, sells and supports the MDISK add-on RAM disk for the Ampro LB. PCB \$29, assembled PCB \$129, includes driver software, manual.

Corvatek, 561 N.W. Van Buren St. Corvallis OR 97330, (503)752-4833. PC style to serial keyboard adapter for Xerox, Kaypros, Franklin, Apples, \$129. Other models supported.

Morgan, Thielmann & Associates services NON-PC compatible computers including CP/M as well as clones. Call Jerry Davis for more information (408) 972-1965.

Jim S. Thale Jr., 1150 Somerset Ave., Deerfield IL 60015-2944, (708)948-5731. Sells I/O board for YASBEC. Adds HD drives, 2 serial, 2 parallel ports. Partial kit \$150, complete kit \$210.

Trio Company of Cheektowaga, Ltd., PO Box 594, Cheektowaga NY 14225, (716)892-9630. Sells CP/M (& PC) packages: InfoStar 1.5 (\$160); SuperSort 1.6 (\$130), and WordStar 4.0 (\$130).

Parts is Parts, Mike Zinkow, 137 Barkley Ave., Clifton NJ 07011-3244, (201)340-7333. Supports Zenith Z-100 with parts and service.

DYNACOMP, 178 Phillips Rd. Webster, NY 14580, (800)828-6772. Supplying versions of CP/M, TRS80, Apple, CoCo, Atari, PC/XT, software for older 8/16 bit systems. Call for older catalog.

# The Computer Journal Back Issues

Sales limited to supplies in stock.

## Volume Number 1:

- Issues 1 to 9
- Serial Interfacing and Modem transfers
- Floppy/disk formats. Print spooler.
- Adding 8067 Math Chip, Aber optics
- S-100 HI-RES graphics.
- Controlling DC motors, Multi-user column.
- VIC-20 EPROM Programmer, CP/M 3.0.
- CP/M user functions and integration.

## Volume Number 2:

- Issues 10 to 19
- Forth tutorial and Write Your Own.
- 68008 CPU for S-100.
- RPM vs CP/M, BIOS Enhancements.
- Poor Man's Distributed Processing.
- Controlling Apple Stepper Motors.
- Facsimile Pictures on a Micro.
- Memory Mapped I/O on a ZX81.

## Volume Number 3:

- Issues 20 to 25
- Designing an 8035 SBC
- Using Apple Graphics from CP/M
- Soldering & Other Strange Tales
- Build an S-100 Floppy Disk Controller WD2797 Controller for CP/M 68K
- Extending Turbo Pascal: series
- Unsoldering: The Arcane Art
- Analog Data Acquisition & Control: Connecting Your Computer to the Real World
- Programming the 8035 SBC
- NEW-DOS: series
- Variability in the BDS C Standard Library
- The SCSI Interface: series
- Using Turbo Pascal ISAM Ales
- The Ampro Little Board Column: series
- C Column: series
- The Z Column: series
- The SCSI Interface: Introduction to SCSI
- Editing the CP/M Operating System
- INDEXER: Turbo Pascal Program to Create an Index
- Selecting & Building a System
- Introduction to Assemble Code for CP/M
- Ampro 186 Column
- ZTime-1: A Real Time Clock for the Ampro Z-80 Little Board

## Volume Number 4:

- Issues 26 to 31
- Bus Systems: Selecting a System Bus
- Using the SB 180 Real Time Clock
- The SCSI Interface: Software for the SCSI Adapter
- Inside Ampro Computers
- NEW-DOS: The CCP Commands (continued)
- ZSIG Comer
- Affordable C Compilers
- Concurrent Multitasking: A Review of DoubleDOS
- 68000 TinyGiant: Hawthorne's Low Cost 16-bit SBC and Operating System
- The Art of Source Code Generation: Disassembling Z-80 Software
- Feedback Control System Analysis: Using Root Locus Analysis & Feedback Loop Compensation
- The C Column: A Graphics Primitive Package
- The Hitachi HD64180: New Life for 8-bit Systems
- ZSIG Comer Command Line Generators and Aliases
- A Tutor Program in Forth: Writing a Forth Tutor in Forth
- Disk Parameters: Modifying the CP/M Disk Parameter Block for Foreign Disk Formats
- Starting Your Own BBS
- Build an A/D Converter for the Ampro Little Board
- HQ64180: Setting the Wart States & RAM Refresh using PRT & DMA
- Using SCSI for Real Time Control
- Open Letter to STD Bus Manufacturers
- Patching Turbo Pascal
- Choosing a Language for Machine Control
- Better Software Alter Design
- MDISK: Adding a 1 Meg RAM Disk to Ampro Little Board, Part 1
- Using the Hitachi hd64180: Embedded Processor Design
- 68000: Why use a new OS and the 68000?

- Detecting the 8087 Math Chip
- Floppy Disk Track Structure
- Double Density Floppy Controller
- ZCPR3 IOP for the Ampro Little Board
- 3200 Hackers' Language
- MDISK: Adding a 1 Meg RAM Disk to Ampro Little Board, Part 2
- Non-Preemptive Multitasking
- Software Timers for the 68000
- Lilliput/Z-Node
- Using SCSI for Generalized I/O
- Communicating with Floppy Disks: Disk Parameters & their variations
- XBIOS: A Replacement BIOS for the SB180
- K-OS ONE and the SAGE: Demystifying Operating Systems
- Remote: Designing a Remote System Program
- The ZCPR3 Comer ARUNZ Documentation

## Issue Number 32:

- 15 copies now available -

## Issue Number 33:

- Data File Conversion: Writing a Filter to Convert Foreign File Formats
- Advanced CP/M: ZCPR3PLUS & How to Write Self Relocating Code
- DataBase: The First in a Series on Data Bases and Information Processing
- SCSI for the S-100 Bus: Another Example of SCSI's Versatility
- A Mouse on any Hardware: Implementing the Mouse on a Z80 System
- Systematic Elimination of MS-DOS Ales: Part 2, Subdirectories & Extended DOS Services
- ZCPR3 Comer ARUNZ Shells & Patching WordStar 4.0

## Issue Number 34:

- Developing a File Encryption System.
- Database: A continuation of the data base primer series.
- A Simple Multitasking Executive: Designing an embedded controller multitasking executive.
- ZCPR3: Relocatable code, PRL files, ZCPR34, and Type 4 programs.
- New Microcontrollers Have Smarts: Chips with BASIC or Forth in ROM are easy to program.
- Advanced CP/M: OS extensions to BDOS and BIOS, RSXs for CP/M 2.2.
- Macintosh Data File Conversion in Turbo Pascal.

## Issue Number 35:

- All This & Modula-2: A Pascal-like alternative with scope and parameter passing.
- A Short Course in Source Code Generation: Disassembling 8088 software to produce modifiable assem. source code.
- Real Computing: The NS32032.
- S-100: EPROM Burner project for S-100 hardware hackers.
- Advanced CP/M: An up-to-date DOS, plus details on file structure and formats.
- REL-Style Assembly Language for CP/M and Z-System. Part 1: Selecting your assembler, linker and debugger.

## Issue Number 36:

- Information Engineering: Introduction.
- Modula-2: A list of reference books.
- Temperature Measurement & Control: Agricultural computer application.
- ZCPR3 Comer Z-Nodes, Z-Plan, Amstrand computer, and ZFILE.
- Real Computing: NS32032 experimenter hardware, CPUs in series, software options.
- SPRINT: A review.
- REL-Style Assembly Language for CP/M & ZSystems, part 2.
- Advanced CP/M: Environmental programming.

## Issue Number 37:

- C Pointers, Arrays & Structures Made Easier Part 1, Pointers.
- ZCPR3 Comer Z-Nodes, patching for NZCOM, ZFILER.

- Information Engineering: Basic Concepts: fields, field definition, client worksheets.
- Shells: Using ZCPR3named shell variables to store date variables.
- Resident Programs: A detailed look at TSRs & how they can lead to chaos.
- Advanced CP/M: Raw and cooked console I/O.
- ZSDOS: Anatomy of an Operating System: Part 1.

## Issue Number 38:

- C Math: Dollars and Cents With C.
- Advanced CP/M: Batch Processing and a NewZEX.
- C Pointers, Arrays & Structures Made Easier Part 2, Arrays.
- Z-System Comer Shells and ZEX, Z-Node Central, system security under Z-Systems.
- Information Engineering: The portable Information Age.
- Computer Aided Publishing: Introduction to publishing and Desk Top Publishing.
- Shells: ZEX and hard disk backups.
- Real Computing: The National Semiconductor NS320XX.
- ZSDOS: Anatomy of an Operating System, Part 2.

## Issue Number 39:

- Programming for Performance: Assembly Language techniques.
- Computer Aided Publishing: The HP LaserJet.
- The Z-System Comer System enhancements with NZCOM.
- Generating LaserJet Fonts: A review of Digi-Fonts.
- Advanced CP/M: Making old programs Z-System aware.
- C Pointers, Arrays & Structures Made Easier Part 3: Structures.
- Shells: Using ARUNZ alias with ZCAL.
- Real Computing: The National Semiconductor NS320XX.

## Issue Number 40:

- Programming the LaserJet: Using the escape codes.
- Beginning Forth Column: Introduction.
- Advanced Forth Column: Variant Records and Modules.
- LINKPRL: Generating the bit maps for PRL files from a RELfile.
- WordTech's d4XL: Writing your own custom designed business program.
- Advanced CP/M: ZEX 5.0xThe machine and the language.
- Programming for Performance: Assembly language techniques.
- Programming Input/Output With C: Keyboard and screen functions.
- The Z-System Comer Remote access systems and BDS C.
- Real Computing: The NS320XX

## Issue Number 41:

- Forth Column: ADTs, Object Oriented Concepts.
- Improving the Ampro LB: Overcoming the 88Mb hard drive limit.
- How to add Data Structures in Forth
- Advanced CP/M: CP/M is hacker's haven, and Z-System Command Scheduler.
- The Z-System Comer Extended Multiple Command Line, and aliases.
- Disk and printer functions with C.
- LINKPRL: Making RSXes easy.
- SCOPY: Copying a series of unrelated files.

## Issue Number 42:

- Dynamic Memory Allocation: Allocating memory at runtime with examples in Forth.
- Using BYE with NZCOM.
- C and the MS-DOS Character Attributes.
- Forth Column: Lists and object oriented Forth.
- The Z-System Comer Genie, BDS Z and Z-System Fundamentals.
- 68705 Embedded Controller Application: A single-chip microcontroller application.
- Advanced CP/M: PluPerfect Writer and using BDS C with REL files.

## Issue Number 43:

- Standardize Your Floppy Disk Drives.
- A New History Shell for ZSystem.
- Heath's HDOS, Then and Now.
- The ZSystem Corner Software update service, and customizing NZCOM.
- Graphics Programming With C: Routines for the IBM PC, and the Turbo C library.
- Lazy Evaluation: End the evaluation as soon as the result is known.
- S-100: There's still life in the old bus.
- Advanced CP/M: Passing parameters, and complex error recovery.

## Issue Number 44:

- Animation with Turbo C Part 1: The Basic Tools.
- Multitasking in Forth: New Micros F68FC11 and Max Forth.
- Mysteries of PC Floppy Disks Revealed: FM, MFM, and the twisted cable.
- DosDisk: MS-DOS disk emulator for CP/M.
- Advanced CP/M: ZMATE and using lookup and dispatch for passing parameters.
- Forth Column: Handling Strings.
- Z-System Comer MEX and telecommunications.

## Issue Number 45:

- Embedded Systems for the Tenderfoot: Getting started with the 8031.
- Z-System Comer Using scripts with MEX.
- The Z-System and Turbo Pascal: Patching TURBO.COM to access the Z-System.
- Embedded Applications: Designing a ZBO RS-232 communications gateway, part 1.
- Advanced CP/M: String searches and tuning Jetfind.
- Animation with Turbo C: Part 2, screen interactions.
- Real Computing: The NS32000.

## Issue Number 46:

- Build a Long Distance Printer Driver.
- Using the 803Ts built-in UART.
- Foundational Modules in Modula 2.
- The Z-System Corner Patching The Word Plus spell checker, and the ZMATE macro text editor.
- Animation with Turbo C: Text in the graphics mode.
- ZBO Communications Gateway: Prototyping and using the ZBO CTC.

## Issue Number 47:

- Controlling Stepper Motors with the 68HC11F
- Z-System Corner ZMATE Macro Language
- Using 8031 Interrupts
- T-1: What it is & Why You Need to Know ZCPR3 & Modula, Too
- Tips on Using LCDs: Interfacing to the 68HC705
- Real Computing: Debugging, NS32 Multitasking & Distributed Systems
- Long Distance Printer Driver correction
- ROBO-SOG 90

## Issue Number 48:

- Fast Math Using Logarithms
- Forth and Forth Assembler
- Modula-2 and the TCAP
- Adding a Bernoulli Drive to a CP/M Computer (Building a SCSI Interface)
- Review of BDS "Z"
- PMATE/ZMATE Macros, Pt. 1
- Z-System Corner Patching MEX-Plus and TheWord, Using ZEX

## Issue Number 49:

- Computer Network Power Protection
- Floppy Disk Alignment w/RTXEB, Pt 1
- Motor Control with the F68HC11
- Home Heating & Lighting, Pt. 1
- Getting Started in Assembly Language
- PMATE/ZMATE Macros, Pt. 2
- Z-System Corner/ Z-Best Software

## Issue Number 50:

- Offload a System CPU with the Z181
- Floppy Disk Alignment w/RTXEB, Pt. 2
- Motor Control with the F68HC11
- Modula-2 and the Command Line
- Home Heating & Lighting, Pt. 2
- Getting Started in Assembly Language, Pt.2
- Local Area Networks
- Using the ZCPR3 IOP
- PMATE/ZMATE Macros, Pt. 3
- Z-System Corner, PCED/ Z-Best Software
- Real Computing, 32FX16, Caches

**Issue Number 51:**

- Introducing the YASBEC
- Floppy Disk Alignment w/RTXEB, Pt 3
- High Speed Modems on Eight Bit Systems
- A Z8 Talker and Host
- Local Area Networks—Ethernet
- UNIX Connectivity on the Cheap
- PC Hard Disk Partition Table
- A Short Introduction to Forth
- Stepped Inference in Embedded Control
- Real Computing, the 32CG160, Swordfish
- PMATE/ZMATE Macros
- Z-System Corner, The Trenton Festival
- Z-Best Software, the Z3HELP System

**Issue Number 52:**

- YASBEC, The Hardware
- An Arbitrary Waveform Generator, Pt. 1
- B.Y.O. Assembler... in Forth
- Getting Started in Assembly Language, Pt. 3
- The NZCOMIOP
- Servos and the F68HC11
- Z-System Corner, Programming for Compatibility
- Z-Best Software
- Real Computing, X10 Revisited
- PMATE/ZMATE Macros
- Home Heating & Lighting, Pt. 3
- The CPU280, A High Performance SBC

**Issue Number 53:**

- The CPU280
- Local Area Networks
- An Arbitrary Waveform Generator
- Zed Fest '91
- Getting Started in Assembly Language
- The NZCOM IOP

**Issue Number 54:**

- B.Y.O. Assembler
- Local Area Networks
- Advanced CP/M
- ZCPR on a 16-Bit Intel Platform
- Real Computing
- Interrupts and the Z80
- 8 MHz on a Ampro
- Hardware Heavenn
- What Zilog never told you about the Supers
- An Arbitrary Waveform Generator
- The Development of TDOS

**Issue Number 55:**

- Fuzzillogy 101
- The Cyclic Redundancy Check in Forth
- The Internetwork Protocol (IP)
- Hardware Heaven
- Real Computing
- Remapping Disk Drives through Virtual BIOS
- The Bumbling Mathematician
- YASMEM

**Issue Number 56:**

- TCJ • The Next Ten Years
- Input Expansion for 8031
- Z-Sys Corner - Zed-Fest
- 4 Connecting IDE Drives to 8-Bit Systems
- 8 Queens in Forth
- Real Computing - Linux, BSD 386, Minix
- Kaypro-84 Direct Ale Transfers
- Analog Signal Generation

**Issue Number 57:**

- Z-Sys Corner - Language Independence
- DR. S-100-the start
- Home Automation with X10
- File Transfer Protocols - Info
- MDISK at 8 MHZ - Ampro Update
- Shell Sort in Forth
- Introduction to Forth
- Z AT Last! - ZCPR on a PC? MYZ80!

**Issue Number 58:**

- Z-Sys Corner - Language Independence II
- Real Computing - Minix, UZI, and GNU
- Affordable Development Tools
- DR. S-100 - Tips and info
- Mr. Kaypro - Move the Reset
- Computing Timer Values - Monostables, C
- Multitasking Forth

**Issue Number 59:**

- Z-Sys Corner - ZMATE MACRO usage
- Moving Forth - Part 1
- Center Fold - IMSAI MPU-A
- Developing Turnkey Forth Applications
- Mr. Kaypro - Versions of Kaypros
- DR S-100-Vendors

**Issue Number 60:**

- Next Ten Years - Part II
- Moving Forth Part II
- Center Fold - IMSAI CPA
- Four for Forth - Forth CPU's
- Debugging Forth
- Z-Sys Corner - 8 years of Z-System
- Mr. Kaypro - Turning a Kaypro II into a IV
- DR. S-100-Letters

**Issue Number 61:**

- Z-Sys Corner - Automating GEnie Mail
- Multiprocessing /6809 part I
- Center Fold - XEROX 820
- QC Using the Commodore 64
- Real Computing - JPEG, WORM, archivers
- Support Groups for Classics
- Operating Systems - CP/M
- Mr. Kaypro - S MHz Upgrade

**Issue Number 62:**

- SCSI EPROM Programmer
- Center Fold - XEROX 820
- DR S-100 - Exploring the S-100 Bus
- Moving Forth part III
- Programming the 6526 CIA
- Reminiscing and Musings - 10th Year
- Modem Scripts

**Issue Number 63:**

- Z-Sys Corner - Failsafe Scripts in 4DOS
- SCSI EPROM Programmer - part II
- Center Fold - XEROX 820
- DR S-100 - Disk Drives and BIOS code
- Multiprocessing Part II
- 6809 Operating Systems
- IDE Drives Part II

**Issue Number 64:**

- Z-Sys Corner - Failsafe Scripts in 4DOS II
- Small-C - Review and comment
- Center Fold - last XEROX 820
- DR S-100 - Disk Drives and BIOS - part II
- Moving Forth Part IV

- Small Systems - 6800/6809 History
- Mr. Kaypro - Sign on and Clock Upgrade
- IDE Drives - Part III

**Issue Number 65:**

- Small System Support - 68xx Serial Comm
- Sinclair ZX81 - Letters and Books
- Center Fold - ZX80/81
- DR S-100 - Christmas letters
- Real Computing - Linux and Linking
- European Beat - AMSTRAD in Europe
- PC/XT Corner - Day-Old Computing
- Little Circuits - Reset Circuits
- Levels of Forth - Selecting a Language

**Issue Number 66:**

- Z-System Corner - Failsafe Scripts in 4DOS
- Real Computing - TCP/IP and OSI
- Small System Support - 'C' and 68xx
- Center Fold - Advent Decoder Board
- DR S-100 - Spring Letters
- Connecting IDE Drives (IDE part IV)
- PC/XT Corner - Day-Old Computing
- Little Circuits - Battery Backup Circuits
- Multiprocessing Part III

**Issue Number 67:**

- European Beat - more AMSTRAD history
- Small System Support - 6800/09 programs
- Center Fold - SS-50/SS-30
- DR S-100 - Trenton/Z-Fest & letters
- Serial Kaypro Interrupts in Forth
- Real Computing - Tiny-TCP and WIN
- Little Circuits - Wire and Cable
- Moving Forth Part 5

**Issue Number 68:**

- Small System Support - Languages
- Center Fold - Pertec/Mits 4PIO
- Z-System Corner II - Intro CP/M and Z-Sys
- PC/XT Corner - A bit of everything - Part I
- Little Circuits - CMOS and RC's
- Multiprocessing Forth Part 4
- Mr. Kaypro - Notes, Repairs, and Macros

**Issue Number 69:**

- Small System Support - 6809 ASM, Flex
- Center Fold - S-100 IDE
- Z-System Corner II - Intro, part 2
- Real Computing - Tiny-TCP
- PC/XT Corner - Stepper Motors and Forth
- DR S-100-Mail Bag
- Moving Forth Part 6
- Mr. Kaypro - Advent Decoder Construction

**Issue Number 70:**

- Small System Support - 6809 ASM
- Center Fold - Jupiter ACE
- Z-System Corner II - Intro part 3
- PC/XT Corner - Stepper Motors & Forth
- DR. S-100-Mail Bag
- Multiprocessing Part 5
- European Beat - 8-bit idiot and AMSTRAD

**Issue Number 71:**

- Computing Hero of 1994 - David Jaffe
- Small System Support - 6809 ASM
- Center Fold - Hayes 80-103A S-100 modem
- Power Supply Basics
- PC/XT Corner - Stepper Motors
- Connecting IDE Drives (5) - GIDE Preview

- DR. S-100 - Generic IDE and CompuPro
- Moving Forth Part 7
- Mr. Kaypro - ROM options
- 8048 Emulator Part 1

**Issue Number 72:**

- Beginning PLD - good and bad
- Small System Support - 'C' and ASM
- Center Fold - Rockwell R65F11
- Playing With Micros - 5 to learn with
- Real Computing - Languages
- Small Tools Part 1 - Forth, 68HC11
- DR S-100 - CompuPro 8080/8086
- Moving Forth Part 7.5
- 8048 Emulator Part 2

**Issue Number 73:**

- \$10 XT - what you can get at a swap meet
- Small System Support - 'C' and ASM
- Center Fold - 640K XT
- IDE Part 6
- Real Computing - Linux
- Small Tools Part II - New Micros F68HC11
- DR S-100 - Trenton and Letters
- PC/XT Corner - software quandaries
- 8048 Emulator Part 3

**Issue Number 74:**

- Antique or Junk - How to judge your system
- Small System Support - 'C' and ASM
- Center Fold - S-100 Power Supply
- Real Computing - Linux and Minix
- AMSTRAD PCW Now
- DR. S-100 - Mailbag
- Mr. Kaypro - Adding Composite Monitors
- Palmtech CPUZ180 - Review
- Disk I/O in Forth
- Moving Forth part 8

**Issue Number 75:**

- The European Beat - East German Z80
- Small System Support - 'C' and ASM
- Center Fold - Standard Bus and I/O
- Moving Forth part 8
- Real Computing - Rick moved
- Embedded Control Using the STD Bus
- DR S-100-Mailbag
- EPROM Simulator
- High-Speed Serial I/O for the Applicard
- Disk I/O in Forth, Pt. 2
- T9600 Source Code (Small Tools)

**Issue Number 76:**

- Real Computing - Minix and more
- PC/XT Corner - Bank Switching/Supercharge
- The European Beat -10 years for user group
- Alternatives to the XT
- DR. S-100 - GIDE and the Jade Bus Probe
- Center Fold - JADE Bus Probe
- PC Time Clock - Improving Accuracy
- PC Security System - Home Security
- Small System Support - 'C' and ASM
- Floppy Disk Problems - design problems

**Issue Number 77:**

- Mr. Kaypro - External Video
- Hands-on with PLD's
- Center Fold - CPU280
- The First TRS-80
- Program This! - the Z80 SIO
- Prime Numbers in C

	U.S. Canada/Mexico Europe/Other				
	(Surface)	(Air)	(Surface)	(Air)	
<b>Subscriptions (CA not taxable)</b>					
1 year (6 issues)	\$24.00	\$32.00	\$34.00	\$34.00	\$44.00
2 years (12 issues)	\$44.00	\$60.00	\$64.00	\$64.00	\$84.00
<b>Back Issues (CA tax)</b>	Shipping + Handling for each issue ordered				
Bound Volumes \$20.00 ea	+\$3.00	+\$3.50	+\$6.50	+\$4.00	+\$17.00
#32 thru #43 are \$3.00 ea.	+\$1.00	+\$1.00	+\$1.25	+\$1.50	+\$2.50
#44 and up are \$4.00ea.	+\$1.25	+\$1.25	+\$1.75	+\$2.00	+\$3.50
Items: _____					
_____ Back Issues Total _____					
California Residents add 7.25% Sales TAX _____					
Shipping Total _____					
Subscription Total _____					
Total Enclosed _____					

Name: \_\_\_\_\_  
Address: \_\_\_\_\_  
\_\_\_\_\_  
Credit Card #---exp / \_\_\_\_\_  
Payment is accepted by check, money order, or Credit Card (M/C, VISA, CarteBlanche, Diners Club). Checks must be in US funds, drawn on a US bank. Credit Card orders can call 1(800) 424-8825.

**TCJ- The Computer Journal**  
P.O. Box 3900, Citrus Heights, CA 95611-3900  
Phone (916) 722-4970 / Fax (916) 722-7480

Regular Feature

Editorial Comment

PLD comments

## The Computer Corner

By Bill Kibler

It has been great not doing the managerial duties of *TCJ*, besides Dave did a wonderful job on the last issue. I think his changes will make *TCJ* just that much better. So thanks for continuing on with *TCJ*, Dave.

### Duties

My duties for *TCJ* are mostly this column and the occasional article. You will find my article on picking embedded programming options elsewhere and is the response to letters and email messages I have received. So if there is some item you need some advice or help on, please drop me a message and I'll see what I can do for you. I think this makes my thirteenth year supporting *TCJ* readers.

### PLD's

I want to thank Robert Brown from Alta Engineering for his great PLD article, not only is he supplying a cheap PLD programmer, but he also explained very clearly the why of using PLD's. One reason I have been down on using PLD's was simply the cost of a programmer. Most of our readers have a mantra that goes something like this: "if it cost more than \$100, I'm not interested!" I think Bob's product stays well within that criteria.

Another point of the article is his explanation of why and when to use PLD's. His figure 5 is exactly what I wanted for showing the main reason to use a PLD. You can see very clearly why it is cost effective to use one in that case. All the parts used in the TIL version are not the 25 cent variety and the number of sockets and trace savings more than make up for the higher cost of the PLD. It is also very common for items like this (clock timing) to get changed as the design progresses. Simple changes in the PLD can mean you are still able to use the same board to achieve your new goals.

Memory decoding is also covered in the article. The only thing he didn't mention was when not to use a PLD. I recently designed a board and used a 139 for it's decoding. The 139 is cheap (\$.19) and does the needed decoding with extra pins to spare. The way to decide is not on cost alone, but on logic reasoning. If you really do need the fine grain memory layout as outlined in the article, a PLD is your only option. Any design using a precise memory map like that is also apt to change many times before your done and burning a new PLD is the only way to go.

I have included the schematic of some decoding I used. You can see how simple my decoding is. The design has two sections, one that talks to the PC BUS and one part that is a standalone 8031. There is a dual ported RAM device which fits between the 8031 and the PC, for buffering data or looking at variables. I thought about using a PLD to replace both decoding parts, since then maybe the cost could be justified. The problem here is that you run out of input or output pins. That means two PLD's would be needed and since the 138/139's are only \$.50 for both, compared to \$2.49 for a single 16V8, PLD's are just too costly. You also need to keep in mind, that this would be the only board in house using a PLD of any type. It is pretty hard to justify a single PLD when the other 30 to 40 boards you make all work fine without them.

You also need to look at the board layout. In my design, the dual ported memory sits in the middle of the board, with circuitry on either side. If I tried to use one part for the cost savings, some of the lines would have to cross the middle of the board, and it was all I could do to get 30 some odd lines from each side to land properly on the memory. Having to run 4 or 5 more lines through this mess might just be impossible. Keeping in mind how the board traces run, is

another reason to use or not use PLD's.

My experience has shown that often these fine grain designs lack real reasoning for their design choice. My 139 is anything but fine grain, you waste tons of memory, are very fixed in your options, and are pretty much stuck in doing it that way forever. Since my design's layout is most likely to never change, never use all the options I provide anyway, these are trade off's I can certainly afford to play with.

That's basically (and has always been) my position. As the design gets more complex and you need more flexibility, going from basic TTL to PLD's changes from overkill to the most appropriate for the application. It's not a black and white choice! Every project can have a time when the design is better suited for one choice over another, but it then could change directions as you continue to develop and polish your project. My stand still remains, that you must know both options to be a cost effective designer in today's market of lean and mean machines.

### Code/Data

While I was looking at the memory layout, I remembered I had to make a small change in the design to use Brad's Camel Forth. Remember that 8031's have separate space for DATA and CODE. Forth needs to run code out of data memory. That means you must combine the two signal lines that control the use of RAM or ROM devices.

The /PSEN signal is used to turn on the ROM device, while the /RD signal is used in talking to regular RAM. Keeping the memory areas separate, means it is possible to have 64K of each memory. My combining of the spaces limits total memory usage to 64K. Now please keep in mind these are suppose to be embedded systems and I have always felt if you needed more than 16 or 20K of ROM,

you must be looking at your design a bit askew.

Implementing the dual use of memory is very simple. There are other ways than the one I use, but two simple diodes work just fine. You need the pull-up resistors to make sure they are biased properly, but overall cost is well under 20 cents. I use a jumper so you can select whether or not the option is in use.

After installing the diodes and resistors, using Camel Forth required that I recompile it for the memory map shown in the schematic. I was then able to burn a ROM, power up and get the OK prompt I then wrote test routines to check out memory and other operations. Camel Forth made hardware testing a breeze and that design problems were not associated with code I made up for the projected use. Several times I burnt new ROMs to test a completely different use only to have it lock up with no output of any kind. I simply put back Camel Forth and got the OK to tell me it was in my new code. A very handy tool!

## linux

My full time duties now encompass doing Unix development. I had some Unix

experience before taking this job and have since discovered how much more complex and involved Unix hacking is from regular programming. To help bring myself up to speed I started using and playing with linux.

If you own a 386/486 system and have some extra hard disk space, loading and using linux is very simple. I have tried several versions of the releases and am still not sure which installation to recommend. For the casual user or just curious experimenter, my favorite is the Mini linux. This version is not recommended by the real linux users since it resides on top of DOS.

linux is so well developed, there are versions for almost any option and system around. Some users in Portugal, I think, wanted a simple version to run under DOS to be able to connect with Internet servers and get their E-mail. The version runs entirely on DOS and fits in a 20 meg subdirectory.

I use it as a simple testing ground and place to un-archive files, all without having to install a full system. It will do X-windows and could do everything a full linux does, but I agree with the others, that if you are doing a full system, partition your hard drives and do it properly. The mini version is just, a simple scaled down, single task system installation. I plan on doing some testing to see if I can use it in place of our expensive windows based X-windows interface to the HP-Unix systems I work on.

## Embedded

I keep seeing various articles and messages about using linux for embedded development. I suppose you can do that, and there are certainly plenty of tools to help you in that idea. I find some features of linux/Unix a bit overkill and restrictive. You can get linux to boot fast, but I find the 5 or so minutes a bit long. You need to remember however, that normally you would boot linux and never shut it down.

For those of us who have grown up doing embedded and hardware work for years, the idea of not being able to just hit the reset switch to get yourself out of a problem seems like a step backwards. The idea behind the bigger systems like linux is memory and hardware protection. Your program can't really get control of what we are so using to dealing with in simpler systems. I find that the big-

gest problem for me.

When dealing with embedded devices, you know where every device is, how memory is laid out, and usually which hex codes are needed to make it play. linux/Unix systems do not allow that sort of access. I look back at several projects and see that using linux would have made the development considerably longer and more difficult.

Since I now do most things in C, my understanding of C is becoming more developed. C really works on systems like linux. You have large libraries that handle all the inner system calls. Those system calls are part of the operating system, and as such give you a direct hook into the system kernel. By that I mean the design of the operating system is based on the use of the libraries. The big difference for embedded use is these same calls just get converted to some assembly language code that gets included into the ROM, making it very bloated with often unused code.

A better way to explain this would be program size needed to do similar processes. Most Unix systems have sharable libraries, this means the code is not sucked into the program, but called at run time, not possible in DOS. So it is possible to make a few hundred byte program in Unix, that would have to have all the actual library calls coded inside the program to run on DOS, since DOS has no sharable option. That is a big difference and also why I don't recommend it for embedded controllers.

For embedded work that means the library code gets sucked into the ROM and thus the ROM can get pretty large. In the case of using Forth, it is more like the linux/Unix idea. The kernel contains or is made up of all the tools you need and you only make calls to them to get things done. It also reminds me of why a lot of CP/M users have trouble understanding the PC architecture. In CP/M and other simple systems, one can grasp and understand the whole system, and thus take advantage of system hooks usually hidden by more complex layers.

That's it...

Well keep hacking till next time. Bill Kibler.

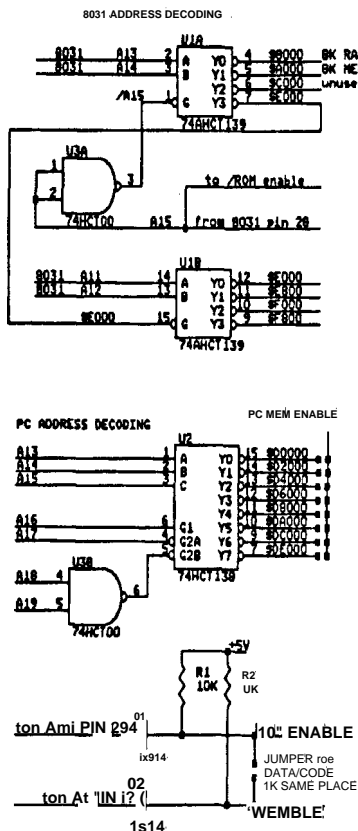

---

---

# TCJ CLASSIFIED - Items Wanted and For Sale

---

---

CLASSIFIED RATES!  
\$5.00 PER LISTING!

*TCJ* Classified ads are on a prepaid basis only. The cost is \$5.00 per ad entry. Support wanted is a free service to subscribers who need to find old or missing documentation or software. Please limit your requests to one type of system.

#### Commercial Advertising Rates:

Size	Once	4+
Full	\$150	\$90
1/2 Page	\$80	\$60
1/3 Page	\$60	\$45
1/4 Page	\$50	\$40
Market Place	\$30	\$120/yr

Send your items to:

The Computer Journal  
P.O. Box 3900

Citrus Heights, CA 95611-3900

**Historically Brewed.** The magazine of the Historical Computer Society. Read about the people and machines which changed our world. Buy, sell and trade "antique" computers. Subscriptions \$18, or try an issue for \$3. HCS, 2962 Park Street #1, Jacksonville, FL 32205.

Start your own technical venture! Don Lancaster's newly updated **INCREDIBLE SECRET MONEY MACHINE** H tells how. We now have autographed copies of the Guru's underground classic for \$21.50. Synergetics Press, Box 809-J, Thatcher AZ, 85552.

#### THE CASE AGAINST PATENTS

Thoroughly tested and proven alternatives that work in the real world. \$33.50. Synergetics Press, Box 809-J, Thatcher AZ, 85552.

**Wanted: Form filling software** for the KayPro CP/M computer. Trying to find "Formation" by PBT software once of Grand Rapids, MI, or "StanForm" by MAP, Micro-Art Programmers. Other software capable of filling out pre-

printed forms considered. Help give a KayPro meaningful work! Please reply to Stephen Stone -Tel. (805)569-8329 or [stephen@silcom.com](mailto:stephen@silcom.com)

**Wanted: Intel SDK-85 documentation.** This is a single board design kit with the 8085 CPU, includes a hex keypad and 7 segment LED readout. I have several of these units and would consider trading for interesting older computers. Ron Wintriss, 100 Highland Ave., Lisbon, NH 03585.

**FOR SALE: Kaypro** hard disk controller cards, WD series for 2/4/10s. Motherboards for all models now in stock. Complete replacement monitors and other new items for your Kaypro needs. Mr. Kaypro, Chuck Stafford. (916) 483-0312, eves/weekends.

**FOR SALE, Motorola Development Kits.** Fuzzy logic (FLEDKT00), 68HC16 (M68HC16TK), and 68HC05 (M68HC705KICS). MAKE OFFER! Other Miscellaneous Electronics available, for a list send SASE to Gene Francisco, 10226 N. 29th St., Tampa, FL 33612. Email [neelrah@cftnet.com](mailto:neelrah@cftnet.com)

**FOR SALE: THE FORTH ARCHIVE** from [taygeta.com](http://taygeta.com) on CDROM is available from Mountain View Press, Rt 2 Box 429, La Honda, CA. 94020 415-747-0760

[ghaydon@forsythe.stanford.edu](mailto:ghaydon@forsythe.stanford.edu).

**FOR SALE: Kaypro 2**, appears to be in good condition, located in Indiana. Call Bob Finch, 317-564-4226.

#### TCJ ADS WORK! 5

Classified ads in *TCJ* get results, FAST!  
Need to sell that special older system - TRY *TCJ*.  
World Wide Coverage with Readers interested in what **YOU** have to sell.  
Provide a support service, our readers are looking for assistance with their older systems - all the time.  
The best deal in magazines, *TCJ Classified* it works!

#### Kibler Electronics

**Hardware Design &  
Software Programming**

8051, 6805, Z80, 68000, x86  
PLC Support and  
Documentation

**Bill Kibler**  
P.O. Box 535  
Lincoln, CA 95648-0535  
(916) 645-1670

e-mail: [kibler@psyber.com](mailto:kibler@psyber.com)  
<http://www.psyber.com/~kibler>

**Discover**

**The Z-Letter**

The Z-letter is the only publication exclusively for CP/M and the Z-System. Eagle computers and Spellbinder support. Licensed CP/M distributor.

Subscriptions: \$18 US, \$22 Canada and Mexico, \$36 Overseas. Write or call for free sample.

The Z-Letter  
 Lambda Software Publishing  
 149 West Hilliard Lane  
 Eugene, OR 97404-3057  
 (541) 688-3563

**Advent Kaypro Upgrades**

**TurboROM.** Allows flexible configuration of your entire system, read/write additional formats and more, only \$35.

Replacement Floppy drives and Hard Drive Conversion Kits. Call or write for availability & pricing.

Call (916)483-0312  
 evenings, weekends or write  
**Chuck Stafford**  
 4000 Norris Ave.  
 Sacramento, CA 95821

**TCJ MARKET PLACE**

Advertising for small business

First Insertion: \$30  
 Reinsertion: \$25  
 Full Six issues \$120

Rates include typesetting.  
 Payment must accompany order.  
 VISA, MasterCard, Diner's Club,  
 Carte Blanche accepted. Checks,  
 money orders must be US funds.  
 Resetting of ad constitutes a new  
 advertisement at first time  
 insertion rates. Mail ad or  
 contact

*The Computer Journal*  
 P.O. Box 3900  
 Citrus Heights, CA 95611-3900  
 (916) 722-4970  
 Fax (916) 722-7480

**CP/M SOFTWARE**

100 page Public Domain Catalog, \$8.50 plus \$1.50 shipping and handling. New CP/M 2.2 manual \$19.95 plus shipping. Also MS-DOS software. Disk Copying including AMSTRAD. Send self addressed, stamped envelope for free Flyer, Catalog \$1.00.

**Elliam Associates**  
 Box 2664  
 Atascadero, CA 93423  
 805-466-8440

**VINTAGE COMPUTERS**

IBM Compatibles  
 Tested - Used Parts for  
 PC/XT AT PS/2  
 Working systems from \$50  
 All parts including  
 cases monitors floppies  
 hard drives MFM RLL IDE  
 Technical Specs  
 Send 5x7 SASE to:  
**Vintage Computers**  
 Paul Lawson  
 1673 Litchfield Turnpike  
 Woodbridge, CT 06525  
 or call for a faxed list  
 203-389-0104

**MORE POWER!**

**68HC11, 80C51 & 80C16B**

- 0 More Microcontrollers.
- 0 Faster Hardware.
- 0 Faster Software.
- 0 More Productive.
- 0 More Tools and Utilities.

Low cost SBCs from \$84. Get it done today! Not next month.

**For brochure or applications:**

**AM Research**  
 P.O. Box 43  
 Loomis, CA 95650-9701  
 (800) 949-8051

<http://www.AMResearch.com>

**VERSATILE 80C32 AND 68HC11  
 SINGLE BOARD COMPUTERS**

The DC8032-1 includes the following:  
 • 11.060 MHz 80C32 processor.  
 • 32K of EPROM.  
 • 4 different memory maps.  
 • Extended BASIC-52 with 28 additional commands.  
 The DC6811\*1 includes the following:  
 • 8MHz MC68HC11 processor.  
 • 32K of EPROM jumper selectable as 216K Eproms.  
 • MBASIC11 with custom analog and digital I/O commands.  
 All units include the following standard features:  
 • 32K of battery-backed RAM.  
 • Real time clock.  
 • 8-channel/8-bit A/D.  
 • Centronics parallel printer port.  
 • 24-bits of digital I/O.  
 • Watch dog timer.  
 • 4 x 6 inch board size.  
 • Operates on a single 9 to 12 volt DC power supply.  
 • 40-pin expansion connector.  
 • RS-232 port.  
 • 30 day money back guarantee.  
 • One year parts and labor warranty.  
 All unit come with a 9 volt DC wall cube, serial cable, users manual, and DC\_TERM terminal software. A utility disk of shareware and freeware is also included at no charge.

D. C. MICROS  
 1843 Sumner Ct.  
 Las Cruces, NM 88001  
 Ph. (505) 524-4029

(140.00 kit or assembled and tested. Add 95.00 shipping and handling plus \$5.00 for COD

**THE FORTH SOURCE**

Hardware & Software

**MOUNTAIN VIEW  
 PRESS**

Glen B. Haydon, M.D.  
 Route 2 Box 429  
 La Honda, CA 94020

(415) 747-0760

<http://www.taygeta.com/jfar/ffivp.html>

**\$79<sup>95</sup>**

**68HC11  
 Single Board  
 Computer  
 SBC-8K**

8K EEPROM for More  
 Program Space!  
 SEN-ac, Optional K  
 Serial EEPROM \$10

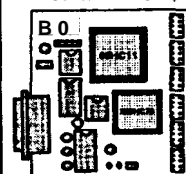

- Small Size, 3.3"x3.6"
- Low Power, <60 ma
- 8192 Bytes EEPROM
- 256 Bytes RAM
- DB-9 RS-232
- 24-TTL I/O Bits
- 8-A/D Inputs
- Power Reset Circuit
- 8Mhz Clock
- Log Data with SER-SC

A Complete 68HC11 Development System.  
 New "CodeLoad+ 2.0" and Sample Programs.  
 No EPROMs or EPROM Programmers!  
 500 Pages of Manuals, 3.5" Utility Disk.

**LDG Electronics Cou**  
 1445 Parran Road Voice/Fax  
 SL Leonard, MD 20685 410-586-2177